



Nika Sanat Steel Industries
Butt Welding Fittings



www.nikasanat.com
E-mail: info@nikasanat.com
nikasanat@gmail.com



Nika Sanat Steel Industries **Steel Buttweing Fittings**

Nika Steel Industries is manufacturer of welded steel joints which started its activity since 1988 under license of Ministry of Industries and Mines and has industrial activity certificate. It has taken step for self -sufficiency of the country with experienced and specialized cadre. This plant started its first production with size of 1.2 inches and promoted its production line to 16 inches of height during this period and it is hoped that we can take larger steps and with use of experienced engineers and diligent technicians as well as through research inside and outside the country and increase our production to 32 inches.

Nika Steel Industries has performed different tests for quality control of its products such as tension test, hydrostatic test and all destructive and nondestructive tests and ultrasonic tests under supervision of well -known companies and presents them with certificate and manufactures its products in accordance with **ASME** and **ANSI** standards. This group is able and ready to do any consultation and order fabrication of all kinds of welded and flanged joints Products of this plant include knee joint three-way joint converter, cap and flange with sizes of 1.2 to 16 inches which are consumed in oil, gas, water, sewage industry and used with ranks of SCH20-SCH40-SCH80-SCH XXS-WPB-WPA and with standard 2441, ASTM A53, ASTM A106 welded and seamless pipes-with DIN 2440

صنایع فولادی جوشی نیکا تولیدکننده اتصالات فولادی جوشی، فعالیت خود را از سال ۱۳۶۷ با مجوز رسمی از وزارت صنایع و معادن آغاز و دارای گواهی فعالیت صنعتی می باشد که با کادری مجرب و متخصص در امر تولید و در راستای خود کفایی قدم نهاده است.

این کارخانه تولید خود را از سایز ۱/۲ اینچ شروع کرده و طی این مدت خط تولید خود را تا ۱۶ اینچ ارتقاء داده است. و با بهره گیری از مهندسين مجرب و تکنسینهای کوشاو پرتوان و همچنین تحقیق و تفحص در داخل و خارج کشور شاهد قدمهای بزرگتری در راستای پیشرفت و تعالی و ارتقای خط تولیدمان تا ۳۶ اینچ باشیم.



صنایع فولادی جوشی نیکا جهت کنترل کیفیت محصولات خود آزمایشات مختلف اتم از تست کشش، تست هیدرواستاتیک و انواع تستهای مخرب و غیر مخرب و التراسونیک رازیر نظر شرکتهای معتبر با **certificat** و محصولات خود را طبق استانداردهای **ANSI** و **ASME** تولید می نماید این مجموعه توانایی انجام هرگونه مشاوره و ساخت انواع اتصالات جوشی و فلنج رانیز دارد.

زانوئی، سه راهی، تبدیل، کپ و فلنج از ۱/۲ اینچ تا ۱۶ اینچ از تولیدات این کارخانه است جهت مصرف در صنعت نفت و گاز، آب و فاضلاب استفاده میگردد که در رده های: **SCH20-SCH40-SCH80 -XXS-WPB-WPA** و بالوله های استاندارد **SEAMLES & WELDED** و با متریهالهای **ASTM A53 - ASTM A106 - 2441 - DIN:2440** تولید میگردد.



Content	Pages
Elbows (Long & Short Radius) to ASME/ANSI B16.9	09-10
Tolerances	11
Welding Bevels & Root Face Seamless Welding Straight & Reducing Outlet Tees to ASME/ANSI B16.9	12-21
Seamless Welding Reducers to ASME/ANSI B16.9	22 - 25
Classes 150 Flanges/Classes 300 Flanges	26 - 29
Ansicaps to ASME/ANSI B16.9	30
The General Material Wrought Carbon Steel Wall Thickness Standard	31 - 33
Technical Parameter A53-A106-A179-A192- 370 -A213-PLS1-API5CT Chemical Components & mechanical property	34 - 37

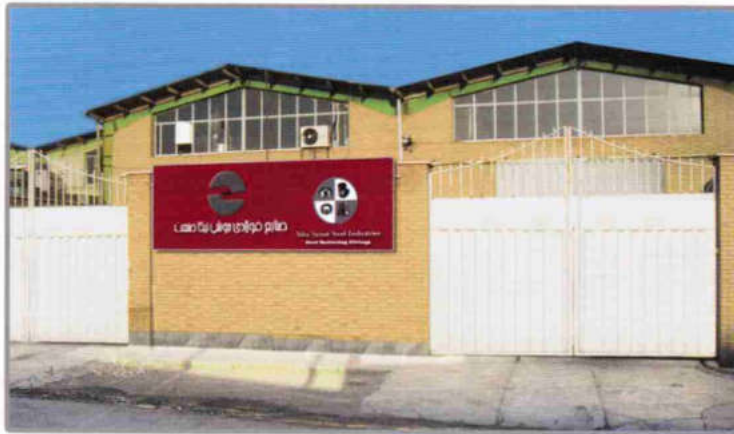

factory



Bent plat



penetrating inspection

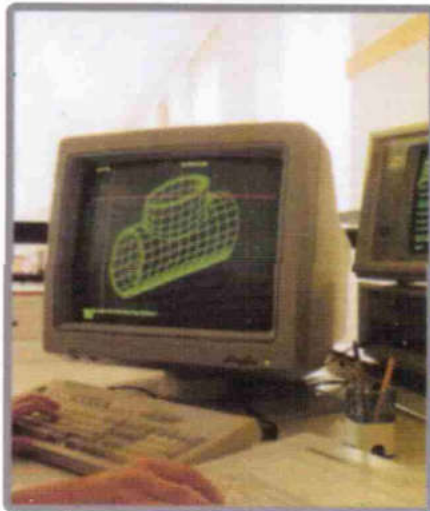

Tee disain

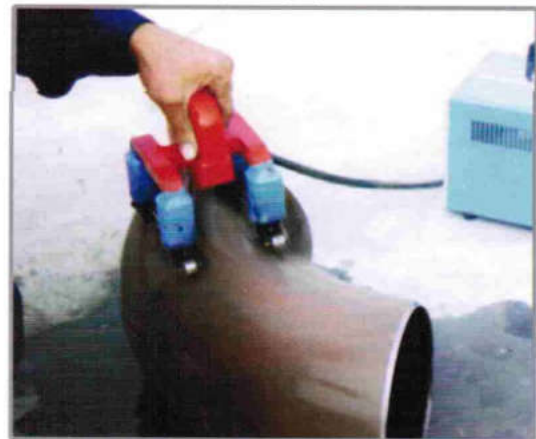

magnetic parted test



Produacts



ultrasonic thickness indicator

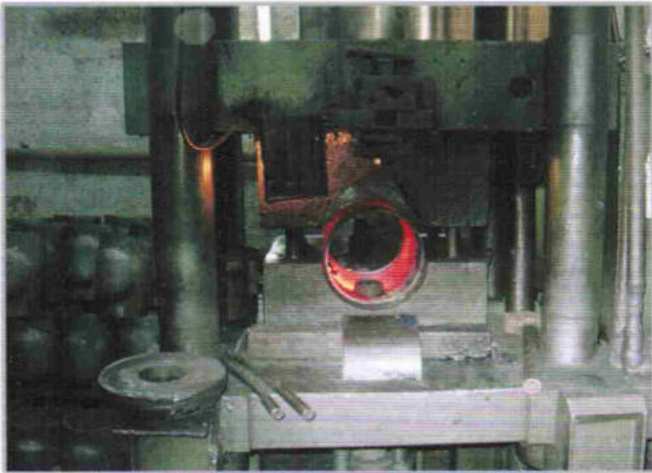

Hydraulic pressure machine

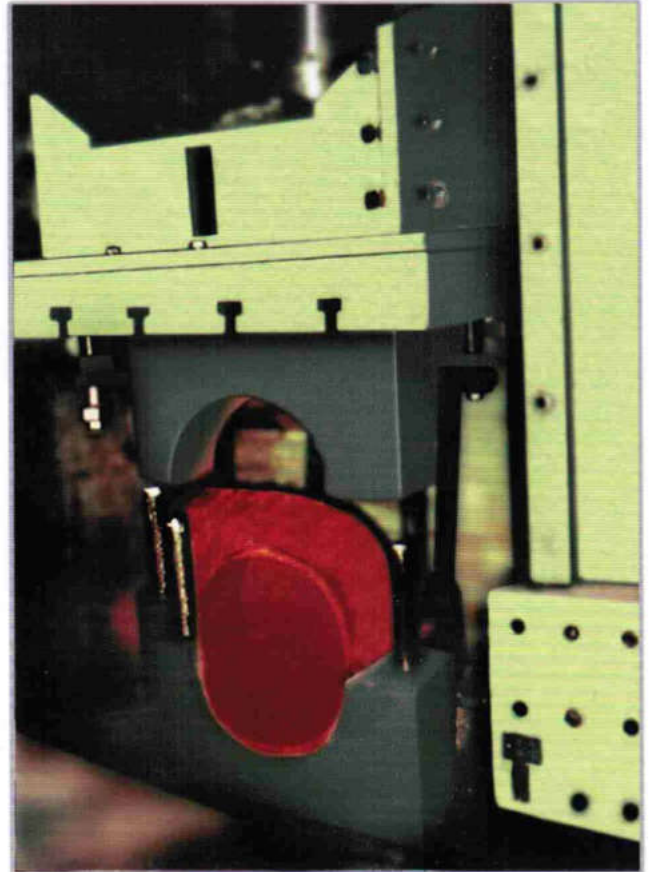

Calibration

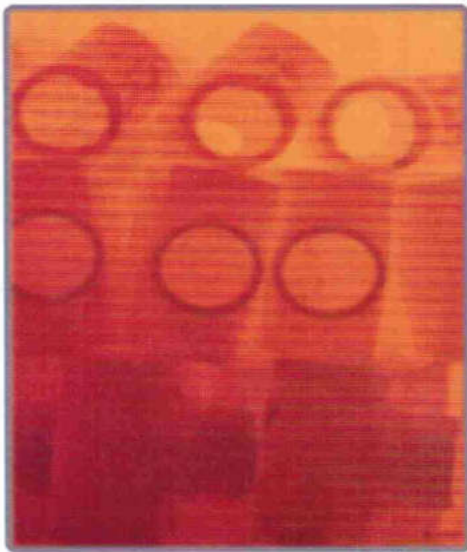

Heat treatment



Intermediate frequency Hot forming

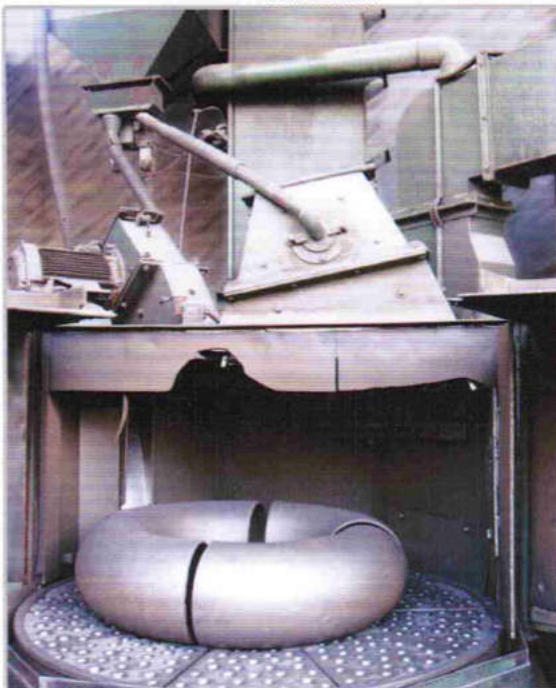

Sand blast machine

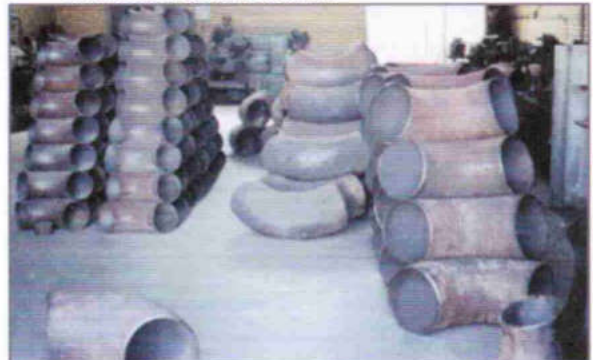

Bevel Forming machine

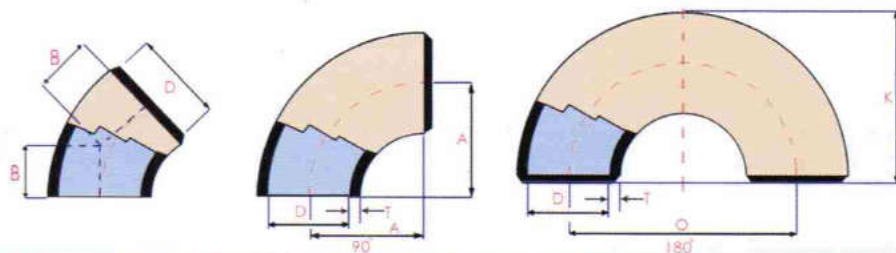

Elbows

Long Radius

ASME/ANSI B16.9

Normal Pipe Size inch	Dimensions			Wall Thickness: t			Approx. Weight	
	Out side Diameter at Bevel: D		Center To End: A/B Center To Center: O Back To Face: D	Sch.No	†		90	kg
	inch	mm	mm		inch	mm		
1/2	0.840	21.3	A=38.1	S5	0.065	1.65	0.05	
			B=15.7	S10	0.083	2.11	0.06	
			O=76.2	std/40 40S	0.109	2.77	0.08	
			K=47.8	XS/80 80S	0.147	2.73	0.10	
				160	0.188	4.78	0.12	
			XXS	0.294	7.47	0.15		
3/4	1.050	26.7	A=38.1	S5	0.065	1.65	0.06	
			B=19.1	S10	0.085	2.11	0.08	
			O=76.2	std/40 40S	0.113	2.87	0.11	
			K=50.8	XS/80 80S	0.154	3.91	0.14	
				160	0.219	5.56	0.17	
			XXS	0.308	7.82	0.22		
1	1.315	33.4	A=38.1	S5	0.065	1.65	0.08	
			B=22.4	S10	0.109	2.77	0.13	
			O=76.2	std/40 40S	0.133	3.38	0.16	
			K=55.6	XS/80 80S	0.179	4.55	0.20	
				160	0.250	6.35	0.25	
			XXS	0.358	9.09	0.26		
1 1/4	1.660	42.2	A=47.8	S5	0.065	1.65	0.21	
			B=25.4	S10	0.109	2.77	0.24	
			O=95.3	std/40 40S	0.140	3.56	0.26	
			K=69.9	XS/80 80S	0.191	4.85	0.35	
				160	0.250	6.35	0.42	
			XXS	0.385	9.70	0.64		
1 1/2	1.900	48.3	A=57.2	S5	0.065	1.65	0.17	
			B=28.4	S10	0.109	2.77	0.26	
			O=114.3	std/40 40S	0.145	3.68	0.37	
			K=82.6	XS/80 80S	0.200	5.08	0.50	
				160	0.281	7.14	0.65	
			XXS	0.400	10.15	0.93		
2	2.375	60.3	A=76.2	S5	0.065	1.65	0.28	
			B=35.1	S10	0.109	2.77	0.45	
			O=152.4	std/40 40S	0.154	3.91	0.66	
			K=106.4	XS/80 80S	0.218	5.54	0.90	
				160	0.344	8.74	1.33	
			XXS	0.436	11.07	1.61		
2 1/2	2.875	73.0	A=95.3	S5	0.083	2.11	0.55	
			B=44.5	S10	0.120	3.05	0.80	
			O=190.5	std/40 40S	0.203	5.16	1.29	
			K=131.8	XS/80 80S	0.276	7.01	1.79	
				160	0.375	9.53	2.33	
			XXS	0.552	14.02	3.43		
3	3.500	88.9	A=114.3	S5	0.083	2.11	0.80	
			B=50.8	S10	0.120	3.05	1.17	
			O=228.5	std/40 40S	0.216	5.49	2.04	
			K=158.8	XS/80 80S	0.300	7.62	2.74	
				160	0.438	11.13	3.83	
			XXS	0.600	15.24	5.25		
4	4.500	114.3	A=152.4	S5	0.083	2.11	1.39	
			B=63.5	S10	0.120	3.05	2.03	
			O=304.8	std/40 40S	0.237	6.02	3.85	
			K=209.6	XS/80 80S	0.337	8.56	5.36	
				120	0.438	11.13	6.78	
			160	0.531	13.49	8.03		
			XXS	0.674	17.12	10.2		
5	5.563	141.3	A=190.5	S5	0.109	2.79	2.82	
			B=79.2	S10	0.134	3.40	3.45	
			O=381.0	std/40 40S	0.258	6.55	6.51	
			K=261.9	XS/80 80S	0.375	9.53	9.27	
				120	0.500	12.70	12.1	
			160	0.625	15.88	14.7		
			XXS	0.750	19.05	17.6		

Note: The bevel can be made according to the special requirements of the customers

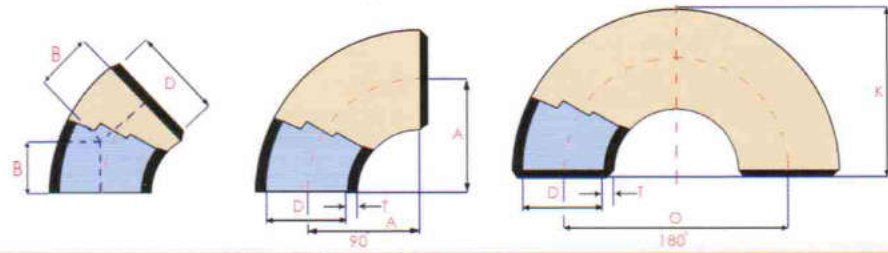

Elbows

Long Radius

ASME/ANSI B16.9

Normal Pipe Size inch	Dimensions		Center To End; A/B Center To Center :o Back To Face: D mm	Sch.No	Wall Thickness: t		Approx. Weight	
	Out side Diameter at Bevel: D				†	90	kg	
	inch	mm						inch
6	6.625	168.3	A=228.6 B=95.3 O=457.2 K=312.7	5S	0.109	2.77	4.10	
				10S	0.134	3.40	4.96	
				Std/40 40S	0.280	7.11	10.10	
				XS/80 80S	0.432	10.97	15.30	
				120	0.562	14.27	19.50	
8	8.625	219.1	A=304.8 B=127.0 O=609.6 K=414.3	160	0.719	18.26	24.20	
				XXS	0.864	21.95	29.10	
				5S	0.109	2.77	7.15	
				10S	0.148	3.76	9.65	
				20	0.250	6.35	15.90	
				30	0.277	7.04	17.60	
				Std/40 40S	0.322	8.18	20.40	
				60	0.406	10.31	25.40	
				XS/80 80S	0.500	12.70	30.90	
				100	0.594	15.09	36.30	
10	10.750	273.0	A=381.0 B=158.8 O=762.0 K=517.7	120	0.719	18.26	43.30	
				140	0.812	20.62	48.30	
				160	0.906	23.01	53.30	
				XXS	0.875	22.23	51.70	
				5S	0.134	3.40	13.70	
				10S	0.165	4.19	16.70	
				20	0.250	6.35	25.00	
				30	0.307	7.80	30.50	
				Std/40 40S	0.365	9.27	36.10	
				XS/60 80S	0.500	12.70	48.80	
12	12.750	323.9	A=457.2 B=190.5 O=914.4 K=619.3	80	0.594	15.09	57.30	
				100	0.719	18.26	68.60	
				120	0.844	21.44	79.50	
				XXS/140	1.000	25.40	92.80	
				160	1.125	28.58	103.00	
				5S	0.156	3.94	23.00	
				10S	0.180	4.57	26.10	
				20	0.250	6.35	35.70	
				30	0.330	8.38	46.80	
				Std/40	0.375	9.53	53.10	
14	14.000	355.6	A=533.4 B=222.3 O=1066.8 K=711.2	40	0.406	10.13	57.80	
				XS/80S	0.500	12.70	70.00	
				60	0.562	14.27	78.20	
				80	0.688	17.48	94.70	
				100	0.844	21.44	115.00	
				120	0.844	21.44	115.00	
				XXS/120	1.000	25.40	134.00	
				140	1.125	28.58	149.00	
				160	1.312	33.32	171.00	
				5S	0.156	3.96	30.80	
14	14.000	355.6	A=533.4 B=222.3 O=1066.8 K=711.2	10	0.188	4.78	36.90	
				20	0.250	6.35	45.80	
				30	0.312	7.92	56.90	
				Std/30	0.375	9.53	68.10	
				40	0.438	11.13	79.20	
				XS	0.500	12.70	90.00	
				60	0.594	15.09	106.00	
				80	0.750	19.05	132.00	
				100	0.938	23.83	163.00	
				120	0.938	23.83	163.00	
XXS/120	1.094	27.79	188.00					
140	1.250	31.75	212.00					
160	1.406	35.71	236.00					

Note: The bevel can be made according to the special requirements of the customers

Elbows
Long Radius
ASME/ANSI B16.9

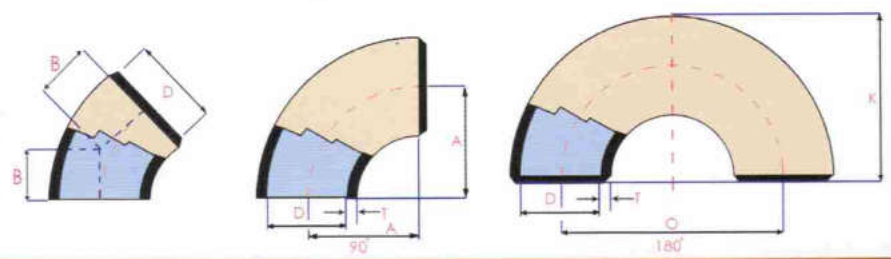

Normal Pipe Size inch	Dimensins		Center To End;A/B Center To Center :o Back To Face:D mm	Sch.No	Wall Thickness:t		Approx.Weight	
	Out side Diameter at Bevel:D				†	90		
	inch	mm				inch	mm	kg
16	16.000	406.4	A=609.3 B=254.0 O=1219.2 K=812.8	5S	0.165	4.19	39.90	
				10S	0.188	7.78	45.50	
				20	0.250	6.35	74.30	
				30	0.312	7.92	60.00	
				Std/40 40S	0.375	9.53	89.50	
				60	0.500	12.70	118.00	
				XS/80 80S	0.656	16.66	153.00	
				100	0.844	21.44	195.00	
				120	1.031	26.19	235.00	
				140	1.219	30.96	274.00	
				160	1.438	36.53	319.00	
				160	1.594	40.49	350.00	
				18	18.000	457.0	A=685.8 B=285.8 O=1371.6 K=914.4	5S
10S	0.188	4.78	57.70					
10	0.250	6.35	76.10					
20	0.312	7.92	94.50					
30	0.438	11.13	113.00					
STD	0.375	9.53	132.00					
XS	0.500	12.70	150.00					
40	0.562	14.27	168.00					
60	0.750	19.05	222.00					
80	0.937	23.83	274.00					
100	1.156	29.36	334.00					
120	1.375	34.93	392.00					
140	1.562	39.67	440.00					
160	1.781	45.24	495.00					
20	20.000	508.0	A=762.0 B=317.5 O=1524.0 K=1016.0	5S	0.188	4.78	71.30	
				10S	0.218	5.54	81.50	
				10	0.250	6.35	94.00	
				20	0.375	9.53	140.00	
				STD20	0.500	12.70	186.00	
				XS30	0.594	15.09	220.00	
				40	0.812	20.62	297.00	
				60	1.031	26.19	372.00	
				80	1.281	32.54	457.00	
				100	1.500	38.10	528.00	
				120	1.750	44.45	609.00	
				160	1.969	50.01	676.00	
				22	22.000	559.0	A=838.2 B=324.9 O=1676.4 K=1117.6	5S
10S	0.218	5.54	98.80					
10	0.250	6.35	114.00					
20	0.375	6.53	170.00					
STD20	0.500	12.70	225.00					
XS30	0.875	22.23	387.00					
40	1.125	28.58	493.00					
60	1.375	34.93	594.00					
80	1.625	41.23	694.00					
100	1.875	47.63	790.00					
140	2.125	53.98	886.00					
160								

Note: The bevel can be made according to the special requirements of the customers



Elbows

Long Radius

ASME/ANSI B16.9

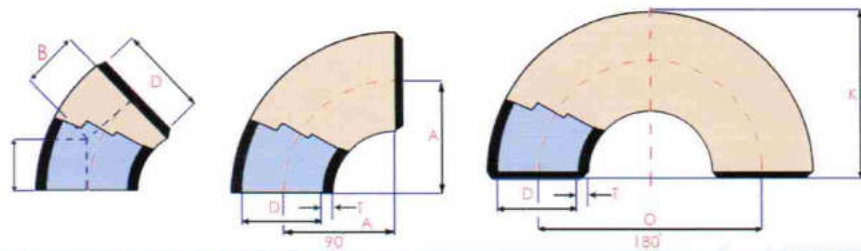

Normal Pipe Size inch	Dimensions			Sch.No	Wall Thickness:t		Approx.Weight	
	Out side Diameter at Bevel:D		Center To End:A/B Center To Center :o Back To Face:D		†	90	kg	
	inch	mm	mm					
24	24.000	610.0	A=914.4 B=381.0 O=1828.8 K=1219.2	5S	0.218	5.54	118.00	
				10S	0.250	6.35	137.00	
				10	0.250	6.35	136.00	
				20	0.375	6.53	202.00	
				STD20	0.500	12.70	269.00	
				XS30	0.562	14.27	301.00	
				40	0.688	17.48	366.00	
				60	0.969	24.61	510.00	
				80	1.219	30.96	636.00	
				100	1.531	38.89	784.00	
				120	1.812	46.02	919.00	
				140	2.062	52.37	1033.00	
160	2.344	59.54	1160.00					
26	26.000	660.0	A=990.6 B=406.4	10	0.312	7.92	198.00	
				std	0.375	9.53	238.00	
				xs/20	0.500	12.70	316.00	
28	28.000	711.0	A=1066.8 B=438.2	10	0.312	7.92	230.00	
				std	0.375	9.53	276.00	
				xs/20	0.500	12.70	367.00	
30	30.000	762.0	A=1143 B=469.9	30	0.625	15.88	456.00	
				s5	0.250	6.35		
				s10	0.312	7.92	264.00	
				std	0.375	9.53	318.00	
32	32.000	813.0	A=1219.2 B=501.7	xs/20	0.500	12.70	421.00	
				30	0.625	15.88	524.00	
				s5	0.312	7.92	301.00	
				10	0.375	9.53	362.00	
34	34.000	864.0	A=1295.4 B=533.4	std	0.500	12.70	480.00	
				30	0.625	15.88	597.00	
				40	0.688	17.48	656.00	
				10	0.312	7.92	340.00	
36	36.000	914.0	A=1371.6 B=56.2	std	0.375	9.53	408.00	
				xs/20	0.500	12.70	543.00	
				30	0.625	15.88	675.00	
				40	0.750	19.05	742.00	
38	38.000	965.0	A=1447.8 B=600.0	10	0.312	7.92	381.00	
				std	0.375	9.53	458.00	
				xs/20	0.500	12.70	608.00	
40	40.000	1016.0	A=1524 B=631.8	30	0.625	15.88	758.00	
				40	0.750	19.05	906.00	
				std/40	0.375	9.53	510.00	
42	42.000	1066.8	A=1600.2 B=660.4	xs/80	0.500	12.70	679.00	
				std/40	0.375	9.53	565.00	
				xs/80	0.500	12.70	753.00	
44	44.000	1107.6	A=1679.4 B=695.3	std/40	0.375	9.53	622.00	
				xs/80	0.500	12.70	828.00	
				std/40	0.375	9.53	684.00	
46	46.000	1168.4	A=1752.6 B=717.1	xs/80	0.500	12.70	912.00	
				std/40	0.375	9.53	748.00	
				xs/80	0.500	12.70	997.00	
48	48.000	1219.2	A=1828.8 B=756.8	std/40	0.375	9.53	814.00	
				xs/80	0.500	12.70	1085.00	

Note: The bevel can be made according to the special requirements of the customers

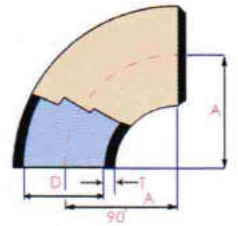
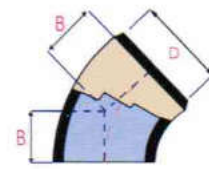
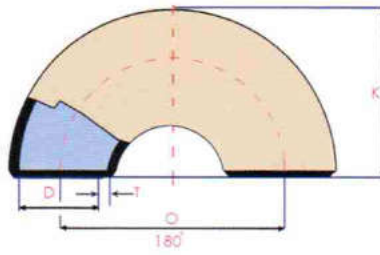

Elbows

Short Radius

ASME/ANSI B16.9

Normal Pipe Size (NPS)	Center - to End									
	Out side Diameter at Bevel OD		180Elbows \bigcirc		180Elbows K		90Elbows A		45Elbows B	
			Short Radius		Short Radius		Short Radius		Short Radius	
	IN	MM	IN	M	IN	MM	IN	MM	IN	M
1/2	0.84	21.3	-	-	-	-	-	-	-	-
3/4	1.05	26.7	-	-	-	-	-	-	-	-
1	1.32	33.4	2	51	1062	41	1	25	0.41	10
1 1/4	1.66	42.2	2.5	64	2.06	52	1.25	32	0.52	13
1 1/2	1.9	48.3	3	76	2.44	62	1.5	38	0.62	16
2	2.38	60.3	4	102	3.19	81	2	51	0.83	21
2 1/2	2.88	73.0	5	127	3.94	100	2.5	64	1.04	26
3	3.5	88.9	6	152	4.75	121	3	76	1.24	32
3 1/2	4	101.6	7	178	5.5	140	3.5	89	1.45	37
4	4.5	114.3	8	203	6.25	159	4	102	1.66	42
5	5.56	141.3	10	254	7.75	197	5	127	2.07	53
6	6.62	168.3	12	305	9.31	237	6	152	2.50	63
8	8.62	219	16	406	12.31	313	8	203	3.31	84
10	10.15	273.0	20	508	15.38	391	10	254	4.14	105
12	12.75	323.8	24	610	18.38	467	12	305	4.97	126
14	14	355.6	28	711	21	533	14	356	5.80	177
16	16	406.4	32	813	24	610	16	406	6.63	168
18	18	457	36	914	27	686	18	457	7.46	189
20	20	508	40	1016	30	762	20	508	8.28	210
22	22	559	44	1118	33	838	22	559	9.11	232
24	24	610	48	1219	36	914	24	610	9.94	253
26	26	660	52	1319	39	975	26	660	10.77	274
28	28	711	56	1421	42	1066	28	711	11.60	295
30	30	762	60	1524	45	1143	30	762	12.43	316
32	32	813	64	1625	48	1219	32	813	14.89	378
34	34	864	68	1728	51	1295	34	864	14.08	358
36	36	914	72	1827	54	1371	36	914	14.91	379
38	38	965	76	1929	57	1447	38	956	15.74	400
40	40	1016	80	2031	60	1523	40	1016	16.57	421
42	42	1067	84	2134	63	1599	42	1067	17.40	442
44	44	1118	88	2236	66	1675	44	1118	18.23	463
46	46	1168	92	2236	69	1751	46	1168	19.05	484
48	48	1219	96	2438	72	1887	48	1219	19.88	505

Kinds	inspection contents	JIS B2311					ASME/ANSI B16.28										
		1/2	3/4	1	2	3	4	5-8	10-18	20-24	1/2	3/4	1	2	3	4	5-8
All Fitting	Out side diameter at bevel D	±2.5	±2.5	±3.5	-50 -4.5	-64 -4.8	+1.52	±1.52	-2.29 -1.52	+4.06 +3.05	-6.35 -4.83						
	inside diameter at end	-20	-2.5	-3.5	±4.5	±4.8	-0.76	±1.52	±1.52	±3.05	±4.83						
	Wall thickness(t)	-15%					-12.5%										
45° 90° Elbow Tees	Center to face (ABCM)	±2.0		±3.2			±1.52		±2.29								
Reducers	Length (H)	±2.0		±3.2													
Caps	Overall Length (E)	±3.2		±6.5			±3.05		±6.35								
180 Returns	Center to center (P)	±6.4		±9.5			±6.35		±9.65								
	Back to face (K)			±6.4					±6.35								
	Deflection of face to face(U)	±1.6		±3.2			±0.76		±1.52								

Tolerances: mm

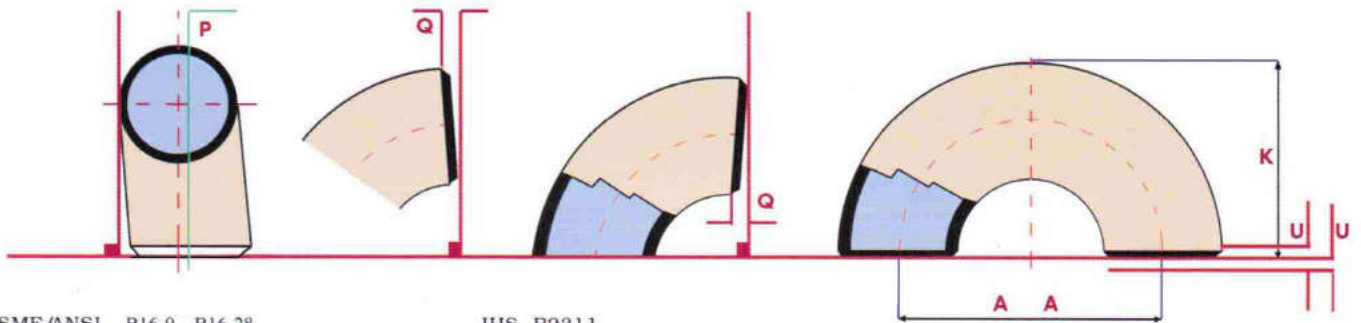

ASME/ANSI B16.9 B16.28

Angularity Tolerance		
Normal Pipe Size	Off Angle	Off Plane
(in)	Q	P
1/2 to 4	0.76	1.52
5 to 8	1.52	3.05
10 to 12	2.29	4.83
14 to 16	2.29	6.35
18 to 24	3.05	9.65

JHS B2311

Angularity Tolerance		
Normal Pipe Size	Off Angle	Off Plane
(in)	Q	P
1/2 to 4	0.8	1.6
5 to 8	1.6	3.2
10 to 12	2.4	4.8
14 to 16	2.4	6.4
18 to 24	3.2	9.5

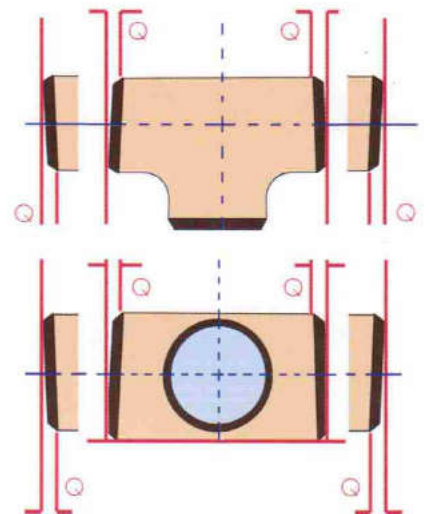

Note: The bevel can be made according to the special requirements of the customers

Welding End Preparation

ASME B16.8, B16.25

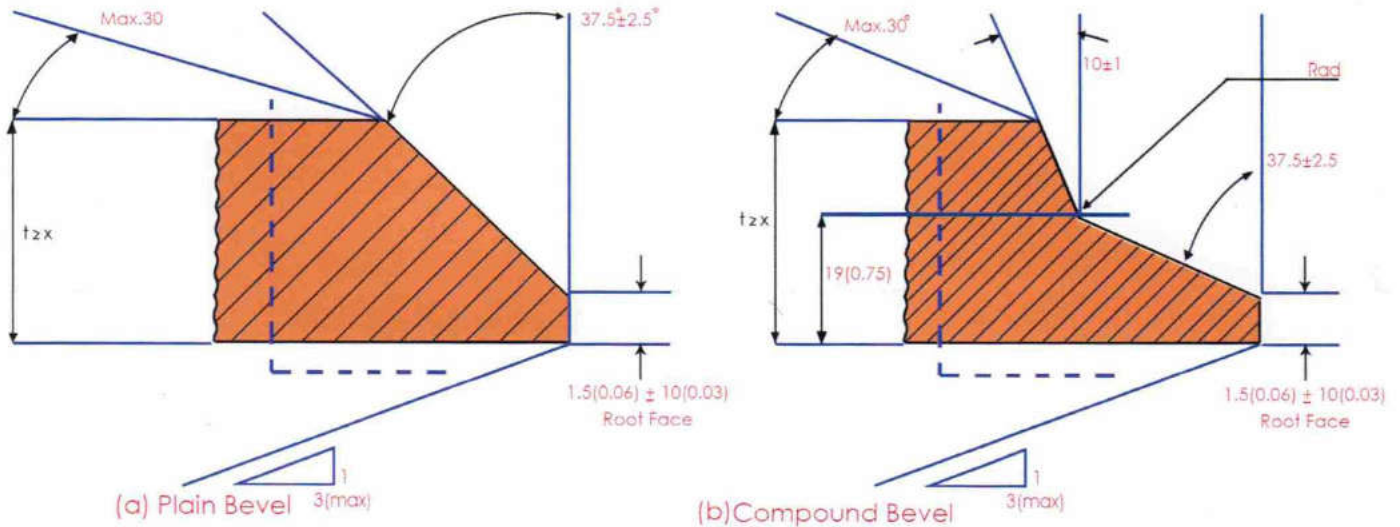

Welding Bevels & Root Face

Normal Wall Thickness, t	End Preparation
Less Than x {note}	Cut Square or slightly chamfer, at manufacturer's option. (not illustrated)
x to 22(0.88) b	Plain Bevel as in sketch (a) Above.
More Than 22(0.88)	Compound bevel as in sketch (b) Above.

GENERAL NOTE: Dimensions in parentheses are in inches. Other are in Millimeters

NOTE: x=5 (0.19) for carbon steel or ferritic alloy steel

X=3 (0.12) for austenitic alloy steel

- Seamless Welding
- Straight & Reducing Outlet Tees
- ASME/ANSI B16.9

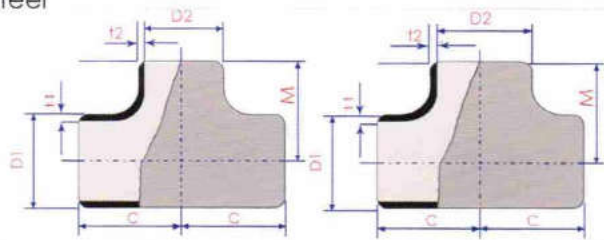

Normal Pipe Size	Dimensions				Wall Thickness-Approx. Weight														
	Out side Diameter at Bevel : D1/D2		Center To End		Sch.20			Sch.30			Std			Sch.40			Sch.60		
	D1	D2	C	M	t1	t2	kg	t1	t2	kg	t1	t2	kg	t1	t2	kg	t1	t2	kg
1.2*1.2	21.3	21.3	25.1	25.1	-	-	-	-	-	-	2.77	2.77	0.40	2.77	2.77	0.40	3.73	3.73	0.55
3.4*1.2	26.7	21.3	29.2	29.2	-	-	-	-	-	-	2.87	2.87	0.45	-	-	-	3.91	3.73	0.60
1*1	33.4	33.4	38.2	38.2	-	-	-	-	-	-	3.38	2.77	0.60	-	-	-	4.55	4.55	-
1*3.4	33.4	26.7	38.2	38.2	-	-	-	-	-	-	3.38	2.87	0.60	-	-	-	4.55	3.92	-
1.2	33.4	29.3	48	48	-	-	-	-	-	-	3.38	2.77	0.60	-	-	-	4.55	3.73	-
11.4*11.4	42.2	42.2	48	48	-	-	-	-	-	-	3.56	3.56	0.75	-	-	-	4.85	4.85	-
11.4*1	42.2	33.4	48	48	-	-	-	-	-	-	3.56	3.38	0.75	-	-	-	4.85	4.55	-
3.4	42.2	26.7	48	48	-	-	-	-	-	-	3.56	2.87	0.75	-	-	-	4.85	8.91	-

Note: The bevel can be made according to the special requirements of the customers

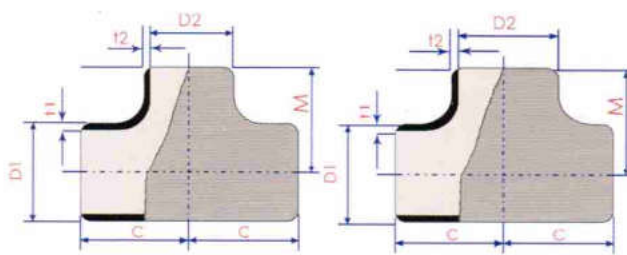

Seamless Welding
Straight & Reducing Outlet Tees
ASME/ANSI B16.9

Normal Pipe Size inch	Dimensions				Wall Thickness-Approx. Weight														
	Out side Diameter at Bevel :D1/D2		Center To End		Sch.20			Sch.30			Std			Sch.40			Sch.60		
	D1 mm	D2 mm	C mm	M mm	t1 mm	t2 mm	kg	t1 mm	t2 mm	kg	t1 mm	t2 mm	kg	t1 mm	t2 mm	kg	t1 mm	t2 mm	kg
1/2*1/2	48.3	48.3	57.2	57.2	-	-	-	-	-	-	3.68	3.68	0.92	3.68	3.68	0.92	-	-	-
2*3/4	60.3	26.7	63.5	44.5	-	-	-	-	-	-	3.91	2.87	1.49	3.91	2.87	1.49	-	-	-
*1	-	33.4	63.5	50.8	-	-	-	-	-	-	-	3.38	1.49	-	3.38	1.49	-	-	-
*1/4	-	42.2	63.5	57.2	-	-	-	-	-	-	-	3.56	1.49	-	3.56	1.49	-	-	-
*1/2	-	48.3	63.5	60.5	-	-	-	-	-	-	-	3.68	1.49	-	3.68	1.49	-	-	-
*2	-	60.3	63.5	63.5	-	-	-	-	-	-	-	3.91	1.49	-	3.91	1.49	-	-	-
2 1/2*1	73.0	33.4	76.2	57.2	-	-	-	-	-	-	5.16	3.38	2.68	5.16	3.38	2.68	-	-	-
*1/4	-	42.2	76.2	63.5	-	-	-	-	-	-	-	3.56	2.68	-	3.56	2.68	-	-	-
*1/2	-	48.3	76.2	66.5	-	-	-	-	-	-	-	3.68	2.68	-	3.68	2.68	-	-	-
*2	-	60.3	76.2	69.9	-	-	-	-	-	-	-	3.91	2.68	-	3.91	2.68	-	-	-
*2 1/2	-	73.0	76.2	76.2	-	-	-	-	-	-	-	5.16	2.68	-	5.16	2.68	-	-	-
3*1 1/4	88.9	42.2	85.9	69.9	-	-	-	-	-	-	5.49	3.56	3.75	5.49	3.56	3.75	-	-	-
*1/2	-	48.3	85.9	73.2	-	-	-	-	-	-	-	3.68	3.75	-	3.68	3.75	-	-	-
*2	-	60.3	85.9	76.2	-	-	-	-	-	-	-	3.91	3.75	-	3.91	3.75	-	-	-
*2 1/2	-	73.0	85.9	82.6	-	-	-	-	-	-	-	5.16	3.75	-	5.16	3.75	-	-	-
*3	-	88.9	85.9	85.9	-	-	-	-	-	-	-	5.49	3.75	-	5.49	3.75	-	-	-
4*1 1/2	114.3	48.3	104.6	85.9	-	-	-	-	-	-	6.02	3.68	6.50	6.02	3.68	6.50	-	-	-
*2	-	60.3	104.6	88.9	-	-	-	-	-	-	-	3.91	6.50	-	3.91	6.50	-	-	-
*2 1/2	-	73.0	104.6	95.3	-	-	-	-	-	-	-	5.16	6.50	-	5.16	6.50	-	-	-
*3	-	88.9	104.6	98.6	-	-	-	-	-	-	-	5.49	6.50	-	5.49	6.50	-	-	-
*4	-	114.3	104.6	104.6	-	-	-	-	-	-	-	6.02	6.50	-	6.02	6.50	-	-	-
5*2	141.3	60.3	124.0	104.6	-	-	-	-	-	-	6.55	3.91	10.00	6.55	3.91	10.00	-	-	-
*2 1/2	-	73.0	124.0	108.0	-	-	-	-	-	-	-	5.16	10.00	-	5.16	10.00	-	-	-
*3	-	88.9	124.0	111.3	-	-	-	-	-	-	-	5.49	10.00	-	5.49	10.00	-	-	-
*4	-	114.3	124.0	117.3	-	-	-	-	-	-	-	6.02	10.00	-	6.02	10.00	-	-	-
*5	-	141.3	124.0	124.5	-	-	-	-	-	-	-	6.55	10.00	-	6.55	10.00	-	-	-
6*2 1/2	168.3	73.0	142.7	120.7	-	-	-	-	-	-	7.11	5.16	13.50	7.11	5.16	13.50	-	-	-
*3	-	88.9	142.7	124.0	-	-	-	-	-	-	-	5.49	13.50	-	5.49	13.50	-	-	-
*4	-	114.3	142.7	130.0	-	-	-	-	-	-	-	6.02	13.50	-	6.02	13.50	-	-	-
*5	-	141.3	142.7	136.7	-	-	-	-	-	-	-	6.55	14.00	-	6.55	14.00	-	-	-
*6	-	168.3	142.7	142.7	-	-	-	-	-	-	-	7.11	14.00	-	7.11	14.00	-	-	-
8*4	219.1	114.3	177.8	155.4	-	-	-	-	-	-	8.18	6.02	24.50	8.18	6.02	24.50	-	-	-
*5	-	141.3	177.8	162.1	-	-	-	-	-	-	-	6.55	24.50	-	6.55	24.50	-	-	-
*6	-	168.3	177.8	168.1	-	-	-	-	-	-	-	7.11	24.50	-	7.11	24.50	-	-	-
*8	-	219.1	177.8	177.8	-	-	-	-	-	-	-	8.18	24.50	-	8.18	24.50	10.31	10.31	31.80

Note: The bevel can be made according to the special requirements of the customer.



Seamless Welding
Straight & Reducing Outlet Tees
ASME/ANSI B16.9

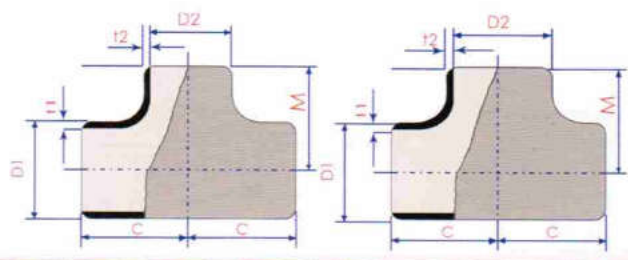

Wall Thickness-Approx.Weight																					Normal Pipe Size (NPS) inch
XS			Sch.80			Sch.100			Sch.120			Sch.140			Sch.160			XXS			
t1 mm	t2 mm	kg	t1 mm	t2 mm	kg	t1 mm	t2 mm	kg	t1 mm	t2 mm	kg	t1 mm	t2 mm	kg	t1 mm	t2 mm	kg	t1 mm	t2 mm	kg	
5.08	5.08	1.27	5.08	5.08	1.27	-	-	-	-	-	-	-	-	-	7.14	7.14	1.79	10.15	10.15	2.54	1 1/2*1 1/2
5.54	3.91	2.15	5.54	3.91	2.15	-	-	-	-	-	-	-	-	-	8.74	5.56	3.18	11.07	7.82	4.00	2*3/4
	4.55	2.15		4.55	2.15	-	-	-	-	-	-	-	-	-		6.35	3.18		9.09	4.00	*1
	4.85	2.15		4.85	2.15	-	-	-	-	-	-	-	-	-		6.35	3.18		9.70	4.00	*1 1/4
	5.08	2.15		5.08	2.15	-	-	-	-	-	-	-	-	-		7.14	3.18		10.15	4.00	*1 1/2
	5.54	2.15		5.54	2.15	-	-	-	-	-	-	-	-	-		8.74	3.18		11.07	4.00	*2
7.01	4.55	2.95	7.01	4.55	2.95	-	-	-	-	-	-	-	-	-	9.53	6.35	3.58	14.02	9.09	4.00	2 1/2*1
	4.85	2.95		4.85	2.95	-	-	-	-	-	-	-	-	-		6.35	3.58		9.70	4.15	*1 1/4
	5.08	2.95		5.08	2.95	-	-	-	-	-	-	-	-	-		7.14	3.58		10.15	4.20	*1 1/2
	5.54	2.95		5.54	2.95	-	-	-	-	-	-	-	-	-		8.74	3.58		11.07	4.20	*2
	7.01	2.95		7.01	2.95	-	-	-	-	-	-	-	-	-		9.53	3.58		14.02	4.50	*2 1/2
7.62	4.85	4.29	7.62	4.85	4.29	-	-	-	-	-	-	-	-	-	11.13	6.35	5.65	15.24	9.70	6.25	3*1 1/4
	5.08	4.29		5.08	4.29	-	-	-	-	-	-	-	-	-		7.14	5.75		10.15	6.30	*1 1/2
	5.54	4.29		5.54	4.29	-	-	-	-	-	-	-	-	-		8.74	5.85		11.07	6.35	*2
	7.01	4.29		7.01	4.29	-	-	-	-	-	-	-	-	-		9.53	6.15		14.02	6.60	*2 1/2
	7.62	4.29		7.62	4.29	-	-	-	-	-	-	-	-	-		11.13	6.58		15.24	7.10	*3
8.56	5.08	7.65	8.56	5.08	7.65	-	-	-	-	-	-	-	-	-	13.49	7.14	10.80	17.12	10.15	14.50	4*1 1/2
	5.54	7.65		5.54	7.65	-	-	-	-	-	-	-	-	-		8.74	10.80		11.07	14.50	*2
	7.01	7.65		7.01	7.65	-	-	-	-	-	-	-	-	-		6.53	10.80		14.02	14.50	*2 1/2
	7.62	7.65		7.62	7.65	-	-	-	-	-	-	-	-	-		11.13	11.10		15.24	14.50	*3
	8.56	7.65		8.56	7.65	-	-	-	11.13	11.13	9.0	-	-	-		13.49	11.80		17.12	15.00	*4
9.53	5.54	13.50	9.53	5.54	13.50	-	-	-	-	-	-	-	-	-	15.88	8.74	23.00	19.05	11.07	27.20	5*2
	7.01	13.50		7.01	13.50	-	-	-	-	-	-	-	-	-		9.53	23.00		14.02	27.20	*2 1/2
	7.62	13.50		7.62	13.50	-	-	-	-	-	-	-	-	-		11.13	23.00		15.24	27.70	*3
	8.56	13.50		8.56	13.50	-	-	-	12.70	11.13	17.50	-	-	-		13.49	23.00		17.12	28.80	*4
	9.53	13.50		9.53	13.50	-	-	-	-	12.70	17.50	-	-	-		15.88	23.00		19.05	29.90	*5
10.97	7.01	19.30	10.97	7.01	19.30	-	-	-	-	-	-	-	-	-	18.26	9.53	30.90	21.95	14.02	34.80	6*2 1/2
	7.62	19.30		7.62	19.30	-	-	-	-	-	-	-	-	-		11.13	30.90		15.24	34.80	*3
	8.56	19.30		8.56	19.30	-	-	-	14.27	11.13	24.00	-	-	-		13.49	32.72		17.12	34.80	*4
	9.53	19.30		9.53	19.30	-	-	-	-	12.70	24.00	-	-	-		15.88	32.70		19.05	35.60	*5
	10.97	19.30		10.97	19.30	-	-	-	-	14.27	24.00	-	-	-		18.26	39.50		21.95	35.60	*6
12.70	8.56	34.70	12.70	8.56	34.70	-	-	-	18.26	11.13	43.20	-	-	-	23.01	13.49	51.00	22.23	17.12	50.40	8*4
	9.53	34.70		9.53	34.70	-	-	-	-	12.70	43.20	-	-	-		15.88	55.60		19.05	50.40	*5
	10.97	34.70		10.97	34.70	-	-	-	-	14.27	49.50	-	-	-		18.26	55.60		21.95	51.30	*6
	12.70	34.70		12.70	34.70	15.09	15.09	43.50	-	18.26	49.50	20.62	20.62	54.00		23.01	58.00		22.23	55.50	*8

Note: The bevel can be made according to the special requirements of the customers.



Seamless Welding

Straight & Reducing Outlet Tees

ASME/ANSI B16.9

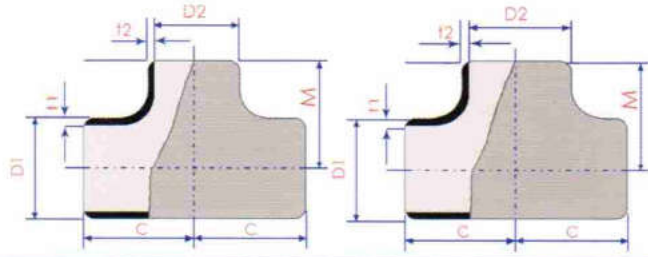

Normal Pipe Size inch	Dimensions				Wall Thickness-Approx.Weight														
	Out side Diameter at Bevel :D ₁ /D ₂		Center To End		Sch.20			Sch.30			Std			Sch.40			Sch.60		
	D ₁ mm	D ₂ mm	C mm	M mm	f1 mm	f2 mm	kg	f1 mm	f2 mm	kg	f1 mm	f2 mm	kg	f1 mm	f2 mm	kg	f1 mm	f2 mm	kg
10*4	273.0	114.3	215.9	184.2	-	-	-	-	-	-	9.27	6.02	36.90	9.27	6.02	39.60	-	-	-
*5		141.3	215.9	190.5	-	-	-	-	-	-		6.55	39.60		6.55	39.60	-	-	-
*6		168.3	215.9	193.5	-	-	-	-	-	-		7.11	39.60		7.11	39.60	-	-	-
*8		219.1	215.9	203.2	6.35	6.35	33.20	7.80	7.04	38.60		8.18	39.60		8.18	39.60	12.70	10.31	53.60
*10		273.0	215.9	215.9		6.35	34.70		7.80	38.60		9.27	41.30		9.27	41.00	-	12.70	58.40
12*5	323.9	141.3	254.0	215.9	-	-	-	-	-	-	9.53	6.55	63.00	10.31	6.55	67.20	-	-	-
*6		168.3	254.0	218.9	-	-	-	-	-	-		7.11	63.00		7.11	67.20	-	-	-
*8		219.1	254.0	228.6	6.35	6.35	41.20	8.38	7.04	54.80		8.18	63.00		8.18	67.20	14.27	10.31	77.50
*10		273.0	254.0	241.3		6.35	43.40		7.80	56.60		9.27	63.00		9.27	70.00		12.70	95.00
*12		323.9	254.0	254.0		6.35	43.40		8.38	56.60		9.53	65.00		10.31	70.50		14.27	95.00
14*6	355.6	168.3	279.4	238.3	-	-	-	-	-	-	9.53	7.11	82.80	11.13	7.11	100.00	-	-	-
*8		219.1	279.4	247.7	7.92	6.35	78.30	9.53	7.04	82.60		8.18	82.80		8.18	100.00	15.09	10.31	127.10
*10		273.0	279.4	257.0		6.35	78.30		7.80	82.60		9.27	82.80		9.27	100.00		12.70	127.10
*12		323.9	279.4	269.7		6.35	80.60		8.38	85.00		9.53	85.00		10.31	105.00		14.27	135.00
*14		355.6	279.4	279.4		7.92	80.60		9.53	85.00		9.53	85.00		11.13	105.00		15.09	135.00
16*6	406.4	168.3	304.8	263.7	-	-	-	-	-	-	9.53	7.11	106.50	12.70	7.11	125.50	-	-	-
*8		219.1	304.8	273.1	7.92	6.35	98.00	9.53	7.04	106.50		8.18	106.50		8.18	125.50	16.66	10.31	160.30
*10		273.0	304.8	282.4		6.35	98.00		7.80	106.50		9.27	106.50		9.27	125.50		12.70	162.80
*12		323.9	304.8	295.1		6.35	100.00		8.38	106.50		9.53	106.50		10.31	129.80		14.27	172.90
*14		355.9	304.8	304.8		7.92	100.00		9.53	110.00		9.53	110.00		11.13	129.80		15.09	172.90
*16		406.4	304.8	304.8		7.92	100.00		9.53	110.00		9.53	110.00		12.70	129.80		16.66	180.50

Note: The bevel can be made according to the special requirements of the customers

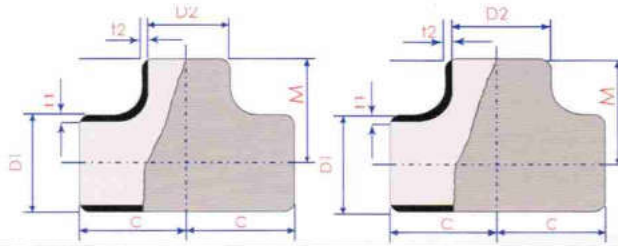

Seamless Welding

Straight & Reducing Outlet Tees

ASME/ANSI B16.9

Wall Thickness-Approx. Weight																					Normal Pipe Size (NPS) inch
XS			Sch.80			Sch.100			Sch.120			Sch.140			Sch.160			XXS			
t1 mm	t2 mm	kg	t1 mm	t2 mm	kg	t1 mm	t2 mm	kg	t1 mm	t2 mm	kg	t1 mm	t2 mm	kg	t1 mm	t2 mm	kg	t1 mm	t2 mm	kg	
12.70	8.56	53.50	15.09	8.56	59.70	-	-	-	21.44	11.13	71.30	-	-	-	28.58	13.49	85.00	25.40	17.12	79.30	10*4
	9.53	53.50		9.53	59.70	-	-	-		12.70	71.30	-	-	-		15.88	91.30		19.05	79.30	*5
	10.97	54.50		10.97	59.70	-	-	-		14.27	81.70	-	-	-		18.26	102.20		21.95	90.90	*6
	12.70	58.40		12.70	65.80	18.26	15.09	73.50		18.26	88.50	24.40	20.92	95.00		23.01	113.00		22.23	90.90	*8
	12.70	58.40		15.09	67.50		18.26	74.00		21.44	93.00		25.40	98.50		28.58	129.3		25.40	98.50	*10
12.70	9.53	74.80	17.48	9.53	85.40	-	-	-	25.40	12.70	102.60	-	-	-	33.32	15.88	140.30	25.40	19.05	119.50	12*5
	10.97	74.80		10.97	85.40	-	-	-		14.27	102.60	-	-	-		18.26	140.30		21.95	119.50	*6
	12.70	74.80		12.70	85.40	21.44	15.09	122.50		18.26	131.20	28.58	20.62	140.00		23.01	152.30		22.23	129.10	*8
	12.70	78.00		15.09	106.20		18.26	124.90		21.44	140.90		25.40	158.00		28.58	163.50		25.40	150.00	*10
	12.70	78.00		17.48	115.00		21.44	136.20		25.40	150.00		28.58	176.50		33.32	183.80		25.40	150.00	*12
12.70	10.97	103.80	19.05	10.97	141.90	-	-	-	27.79	14.27	205.00	-	-	-	35.71	18.26	250.00				14*6
	12.70	103.80		12.70	141.90	23.85	15.09	195.00		18.26	220.00	31.75	20.62	230.00		23.01	250.00				*8
	12.70	103.80		15.09	160.00		18.26	195.00		21.44	220.00		25.40	245.00		28.58	265.00				*10
	12.70	108.90		17.48	162.30		21.44	206.00		25.40	235.00		28.58	255.00		33.32	270.00				*12
	12.70	108.90		19.05	162.30		23.83	206.00		27.79	235.00		31.75	255.00		35.71	270.00				*14
12.70	10.97	130.50	21.44	10.97	163.90	-	-	-	30.96	14.27	265.40	-	-	-	40.49	18.26	320.80				16*6
	12.70	130.50		12.70	163.90	26.19	15.09	229.80		18.26	265.40	36.53	20.62	295.00		23.01	322.00				*8
	12.70	130.50		15.09	163.90		18.26	229.00		21.44	280.00		25.40	300.00		28.58	330.50				*10
	12.70	134.00		17.48	181.60		21.44	258.20		25.40	280.00		28.58	310.00		33.32	340.00				*12
	12.70	135.50		19.05	195.00		23.83	266.50		27.79	295.00		31.75	340.00		35.71	360.00				*14
	12.70	138.50		21.44	195.00		26.19	270.60		30.96	295.00		36.53	360.00		40.49	389.00				*16

Note: The bevel can be made according to the special requirements of the customers

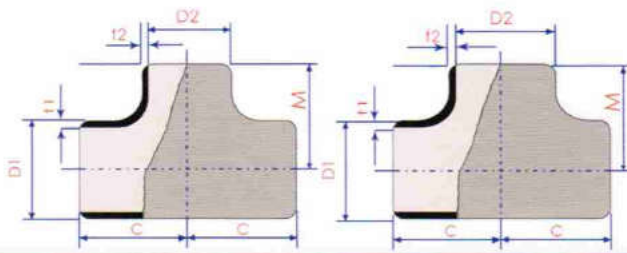

Seamless Welding

Straight & Reducing Outlet Tees

ASME/ANSI B16.9

Normal Pipe Size inch	Dimensions				t	Approx Weight kg	t	Approx Weight kg
	Out side Diameter at Bevel :D1/D2		Center To End					
	D1 mm	D2 mm	C mm	M mm				
18*18	457*457		343*343		std	105.4	XS	130.8
*16	*406		*330		std	102.1	XS	126.8
*14	*356		*330		std	100.6	XS	124.9
*12	*321		*321		std	98.7	XS	122.6
*10	*270		*308		std	96.4	XS	119.6
*8	*217		*295		std	94.3	XS	117.1
20*20	*508*508		381*381		std	130.4	XS	159.7
*18	*457		*368		std	126.8	XS	157.5
*16	*406		*356		std	123.7	XS	153.6
*14	*356		356		std	122.2	XS	151.8
*12	*324		*346		std	120.3	XS	149.4
*10	*273		*333		std	119.3	XS	148.2
*8	*219		*324		std	118.3	XS	146.9
22*22	559*559		419*419		std	158.2	XS	196.6
*20	*508		*406		std	154.1	XS	191.6
*18	*457		*394		std	150.7	XS	187.3
*16	*406		*381		std	147.4	XS	183.2
*14	*356		*381		std	145.9	XS	181.3
*12	*324		*371		std	144.0	XS	179.0
*10	*237		*359		std	141.7	XS	178.7
24*24	610*610		432*432		std	175.3	XS	218.0
*22	*559		*432		std	173.4	XS	215.6
*20	*508		*419		std	168.8	XS	210.8
*18	*457		*406		std	166.1	XS	206.6

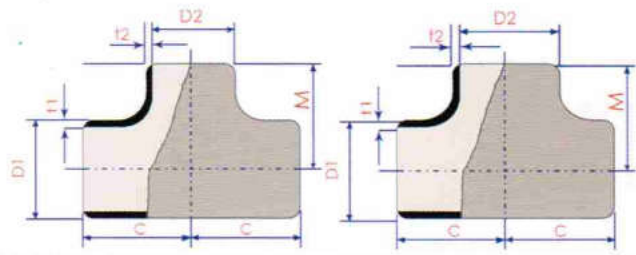

Seamless Welding

Straight & Reducing Outlet Tees

ASME/ANSI B16.9

Normal Pipe Size	Dimensions				†	Approx Weight kg	†	Approx Weight kg
	Out side Diameter at Bevel :D ₁ /D ₂		Center To End					
	D ₁ mm	D ₂ mm	C mm	M mm				
24*16	610*406		432*406		std	164.6	XS	204.7
*14	*356		*406		std	163.1	XS	202.8
*12	*324		*397		std	161.3	XS	200.6
*10	*273		*384		std	158.9	XS	187.6
26*26	660*660		495*495		std	221.8	XS	275.9
*24	*610		*483		std	217.2	XS	270.2
*22	*559		*470		std	212.8	XS	264.7
*20	*508		*457		std	208.8	XS	257.3
*18	*457		*444		std	205.1	XS	255.2
*16	*406		*432		std	202.0	XS	251.3
*14	*356		*432		std	200.5	XS	249.4
*12	*324		*422		std	198.6	XS	247.1
28*28	711*711		521*521		std	249.7	XS	310.7
*26	*660		*521		std	247.2	XS	307.6
*24	*610		*508		std	242.4	XS	301.7
*22	*559		*495		std	238.0	XS	296.2
*20	*508		*483		std	234.1	XS	291.4
*18	*451		*470		std	230.5	XS	286.9
*16	*406		*457		std	227.3	XS	282.8
*14	*356		*457		std	225.8	XS	280.9
*12	*324		*448		std	224.0	XS	278.7
30*30	762*762		559*559		std	287.5	XS	357.9
*28	*711		*546		std	282.1	XS	351.2
*26	*660		*546		std	279.6	XS	348.1

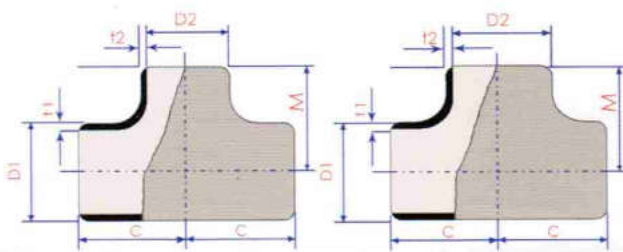

Seamless Welding

Straight & Reducing Outlet Tees

ASME/ANSI B16.9

Normal Pipe Size inch	Dimensions				t	Approx Weight kg	t	Approx Weight kg
	Out side Diameter at Bevel :D1/D2		Center To End					
	D1 mm	D2 mm	C mm	M mm				
30*24	762*610		559*533		std	274.9	XS	342.2
*22	*559		*521		std	270.7	XS	336.9
*20	*508		*508		std	266.7	XS	331.9
*18	*457		*495		std	263.7	XS	327.4
*16	*406		*483		std	259.9	XS	323.5
*14	*356		*483		std	258.4	XS	321.6
*12	*324		*473		std	256.5	XS	319.3
*10	*273		*460		std	249.0	XS	316.3
32*32	813*813		597*597		std	328.0	XS	408.5
30	*762		*584		std	322.3	XS	401.3
*28	*711		*572		std	317.1	XS	394.9
*26	*660		*572		std	314.6	XS	391.8
*24	*610		*559		std	309.9	XS	385.8
*22	*559		*546		std	305.5	XS	380.3
*20	*508		*533		std	301.4	XS	375.3
*18	*457		*521		std	297.9	XS	371.0
*16	*406		*508		std	294.7	XS	367.0
*14	*356		*508		std	293.2	XS	365.1
34*34	864*864		635*635		std	371.2	XS	462.4
*32	*813		*622		std	365.1	XS	454.7
*30	*762		*610		std	359.5	XS	447.8
*28	*711		*597		std	354.2	XS	441.1
*26	*660		*597		std	351.7	XS	438.0
*24	*610		*584		std	346.9	XS	432.1

Note: The bevel can be made according to the special requirements of the customers.



Seamless Welding

Straight & Reducing Outlet Tees

ASME/ANSI B16.9

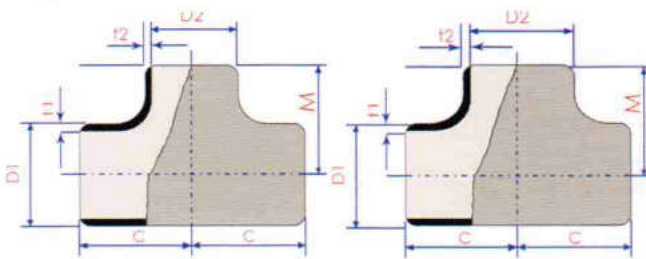

Normal Pipe Size inch	Dimensions				Sch.No.	Approx Weight kg	Sch.No.	Approx Weight kg
	Cut side Diameter of Bevel: D1/D2		Center To End					
	D1 mm	D2 mm	C mm	M mm				
34*22	864	*559	635	*572	std	342.7	XS	426.8
*20	*508	*559			std	338.7	XS	421.8
*18	*457	*546			std	335.1	XS	417.3
*16	*406	*533			std	331.8	XS	413.3
36*36	914	*914	673	*673	std	416.7	XS	519.2
*34	*864	*660			std	410.3	XS	511.1
*32	*813	*648			std	404.4	XS	503.8
*30	*762	*635			std	398.6	XS	496.6
*28	*711	*622			std	393.2	XS	519.9
*26	*660	*622			std	390.7	XS	516.7
*24	*610	*610			std	386.2	XS	511.1
*22	*559	*597			std	381.8	XS	502.9
*20	*508	*584			std	377.7	XS	500.5
*18	*457	*572			std	374.2	XS	496.2
*16	*406	*559			std	371.0	XS	492.1
38*38	965	*965	711	*711	std	465.3	XS	579.7
*36	*914	*711			std	461.8	XS	575.4
*34	*864	*698			std	455.1	XS	568.3
*32	*813	*686			std	449.1	XS	559.5
*30	*762	*673			std	443.1	XS	552.1
*28	*711	*648			std	435.1	XS	542.1
*26	*660	*648			std	432.6	XS	538.9
*24	*610	*635			std	427.8	XS	533.0
*22	*559	*622			std	423.4	XS	527.5

Normal Pipe Size inch	Dimensions				Sch.No.	Approx Weight kg	Sch.No.	Approx Weight kg
	Cut side Diameter of Bevel: D1/D2		Center To End					
	D1 mm	D2 mm	C mm	M mm				
38*20	965	*508	711	*610	std	419.5	XS	424.1
*18	*457	*597			std	415.9	XS	419.6
40*40	1016	*1016	749	*749	std	516.4	XS	643.6
*38	*965	*749			std	512.8	XS	639.1
*36	*914	*737			std	502.6	XS	620.5
*34	*864	*724			std	499.3	XS	612.2
*32	*813	*711			std	489.9	XS	604.3
*30	*762	*698			std	487.0	XS	596.9
*28	*711	*673			std	479.5	XS	586.9
*26	*660	*673			std	476.5	XS	583.8
*24	*610	*660			std	471.7	XS	577.9
*22	*559	*648			std	467.5	XS	572.6
*20	*508	*635			std	463.5	XS	567.9
*18	*457	*622			std	459.9	XS	563.1
42*42	1067	*1067	*762		std	546.9	XS	681.7
*40	*1016	*711			std	528.3	XS	658.5
*38	*968	*711			std	525.8	XS	655.3
*36	*914	*711			std	522.9	XS	651.8
*34	*864	*711			std	520.3	XS	648.1
*32	*813	*711			std	517.6	XS	645.2
*30	*762	*711			std	514.9	XS	641.8
*28	*711	*698			std	509.6	XS	635.1
*26	*660	*698			std	507.1	XS	632.0
*24	*610	*660			std	497.9	XS	620.6

Note: The bevel can be made according to the special requirements of the customers



Seamless Welding

Straight & Reducing Outlet Tees

ASME/ANSI B16.9

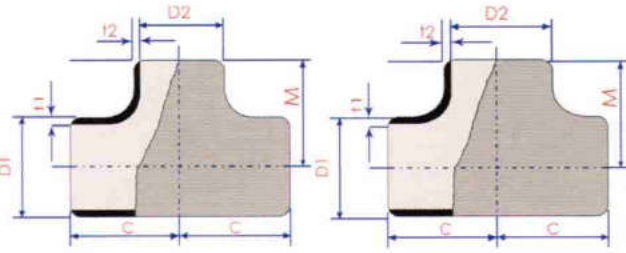

Normal Pipe Size	Dimensions				Sch.No.	Approx Weight kg	Sch.No.	Approx Weight kg
	Out side Diameter at Bevel D1/D2		Center to End					
	D1 mm	D2 mm	C mm	M mm				
42*22	1067*559	762*660	std	496.0	XS	618.2		
*20	*508	*660	std	494.1	XS	615.8		
*18	*457	*648	std	490.6	XS	611.5		
16	*406	*635	std	487.4	XS	607.5		
44*44	1118*1118	813*762	std	598.3	XS	745.9		
*42	*1067	*762	std	595.3	XS	742.1		
*40	*1016	*749	std	588.4	XS	733.4		
*38	*965	*737	std	582.1	XS	725.6		
*36	*914	*724	std	576.0	XS	720.0		
*34	*864	*724	std	573.5	XS	714.9		
*32	*813	*711	std	567.9	XS	708.0		
*30	*762	*711	std	565.6	XS	705.1		
*28	*711	*698	std	560.7	XS	698.9		
*26	*660	*698	std	558.6	XS	696.3		
*24	*610	*698	std	556.5	XS	693.7		
*22	*559	*686	std	552.5	XS	688.7		
*20	*508	*686	std	550.6	XS	686.3		
46*46	1168*1168	851*800	std	655.8	XS	817.7		
*44	*1118	*800	std	652.6	XS	813.7		
*42	*1067	*787	std	645.3	XS	804.5		
*40	*1016	*775	std	638.7	XS	796.3		
*38	*965	*762	std	632.1	XS	788.1		
*36	*914	*762	std	629.5	XS	784.7		
*34	*864	*749	std	623.6	XS	777.4		

Normal Pipe Size	Dimensions				Sch.No.	Approx Weight kg	Sch.No.	Approx Weight kg
	Out side Diameter at Bevel D1/D2		Center to End					
	D1 mm	D2 mm	C mm	M mm				
46*32	1168*813	851*749	std	638.4	XS	774.3		
*30	*762	*737	std	615.9	XS	767.8		
*28	*711	*737	std	613.6	XS	764.9		
*26	*660	*737	std	611.3	XS	762.1		
*24	*610	*724	std	606.7	XS	756.4		
*22	*559	*724	std	604.6	XS	753.7		
48*48	1216*1219	889*838	std	716.3	XS	893.2		
*46	*1168	*838	std	712.9	XS	888.9		
*44	*1118	*838	std	709.5	XS	884.7		
*42	*1067	*813	std	698.3	XS	870.6		
*40	*1067	*813	std	698.3	XS	870.6		
*38	*965	*813	std	692.1	XS	863.0		
*36	*914	*787	std	682.1	XS	850.5		
*34	*864	*787	std	679.5	XS	847.2		
*32	*813	*787	std	676.8	XS	843.9		
*30	*762	*762	std	668.8	XS	833.9		
*28	*711	*762	std	666.5	XS	831.0		
*26	*660	*762	std	664.2	XS	828.1		
*24	*610	*737	std	675.5	XS	819.8		
*22	*610	*737	std	655.6	XS	817.3		

Note: The bevel can be made according to the special requirements of the customers

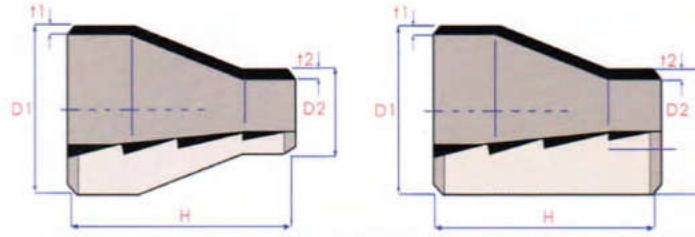

Seamless Welding reducers
ASME/ANSI B16.9

Normal Pipe Size inch	Dimensions			Wall Thickness-Approx.Weight														
	Out side Diameter at Bevel :D1/D2		End To End H mm	Sch.20			Sch.30			Std			Sch.40			Sch.60		
	D1 mm	D2 mm		t1 mm	t2 mm	kg	t1 mm	t2 mm	kg	t1 mm	t2 mm	kg	t1 mm	t2 mm	kg	t1 mm	t2 mm	kg
1*3/4	33.4	26.7	50.8	-	-	-	-	-	-	3.38	2.87	0.14	3.38	2.87	0.14	-	-	-
1 1/2*3/4	48.3	26.7	63.5	-	-	-	-	-	-	3.68	2.87	0.22	3.68	2.87	0.22	-	-	-
*1		33.4	63.5	-	-	-	-	-	-		3.38	0.24		3.38	0.24	-	-	-
*1 1/4		42.2	63.5	-	-	-	-	-	-		3.56	0.26		3.56	0.26	-	-	-
2*1	60.3	33.4	76.2	-	-	-	-	-	-	3.91	3.38	0.37	3.91	3.38	0.37	-	-	-
*1 1/4		42.2	76.2	-	-	-	-	-	-		3.56	0.39		3.56	0.39	-	-	-
*1 1/2		48.3	76.2	-	-	-	-	-	-		3.68	0.41		3.68	0.41	-	-	-
2 1/2*1 1/4	73.0	42.2	88.9	-	-	-	-	-	-	5.16	3.56	0.67	5.16	3.56	0.67	-	-	-
*1 1/2		48.3	88.9	-	-	-	-	-	-		3.68	0.68		3.68	0.68	-	-	-
*2		60.3	88.9	-	-	-	-	-	-		3.91	0.73		3.91	0.73	-	-	-
3*1 1/2	88.9	48.3	88.9	-	-	-	-	-	-	5.49	3.68	0.86	5.49	3.68	0.86	-	-	-
*2		60.3	88.9	-	-	-	-	-	-		3.91	0.91		3.91	0.91	-	-	-
*2 1/2		73.0	88.9	-	-	-	-	-	-		5.16	0.98		5.16	0.98	-	-	-
4*2	114.3	60.3	101.6	-	-	-	-	-	-	6.02	3.91	1.44	6.02	3.91	1.44	-	-	-
*2 1/2		73.0	101.6	-	-	-	-	-	-		5.16	1.52		5.16	1.52	-	-	-
*3		88.9	101.6	-	-	-	-	-	-		5.49	1.59		5.49	1.59	-	-	-
5*2 1/2	141.3	73.0	127.0	-	-	-	-	-	-	6.55	5.16	2.51	6.55	5.16	2.51	-	-	-
*3		88.9	127.0	-	-	-	-	-	-		5.49	2.60		5.49	2.60	-	-	-
*4		114.3	127.0	-	-	-	-	-	-		6.02	2.72		6.02	2.72	-	-	-
6*3	168.3	88.9	139.7	-	-	-	-	-	-	7.11	5.49	3.63	7.11	5.49	3.63	-	-	-
*4		114.3	139.7	-	-	-	-	-	-		6.02	3.72		6.02	3.72	-	-	-
*5		141.3	139.7	-	-	-	-	-	-		6.55	3.93		6.55	3.93	-	-	-
8*4	219.1	114.3	152.4	-	-	-	-	-	-	8.18	6.02	5.95	8.18	6.02	5.95	-	-	-
*5		141.3	152.4	-	-	-	-	-	-		6.55	6.08		6.55	6.08	-	-	-
*6		168.3	152.4	-	-	-	-	-	-		7.11	6.31		7.11	6.31	-	-	-
10*5	273.0	141.3	177.8	-	-	-	-	-	-	9.27	6.55	9.90	9.27	6.55	9.90	-	-	-
*6		168.3	177.8	-	-	-	-	-	-		7.11	10.10		7.11	10.10	-	-	-
*8		219.1	177.8	6.35	6.35	7.89	7.80	7.04	9.62		8.18	10.50		8.18	10.50	12.70	10.31	-
12*6	323.9	168.3	203.2	-	-	-	-	-	-	9.53	7.11	14.10	10.31	7.11	16.50	-	-	-
*8		219.1	203.2	6.35	6.35	10.70	8.38	7.04	14.00		8.18	14.60		8.18	17.20	14.27	10.31	23.50
*10		273.0	203.2		6.35	11.10		7.80	14.60		9.27	15.20		9.27	17.80		12.70	24.30
14*8	355.6	219.1	330.2	7.95	6.35	23.10	9.53	7.04	27.60	9.53	8.18	26.00	11.13	8.18	32.10	15.09	10.31	43.10
*10		273.0	330.2		6.35	24.20		7.80	29.00		9.27	27.40		9.27	33.70		12.70	45.10
*12		323.9	330.2		6.35	25.60		8.38	30.60		9.53	28.80		10.31	35.60		14.27	47.70
16*8	406.4	219.1	355.6	7.95	6.35	27.70	9.53	7.04	33.20	9.53	8.18	31.90	12.70	8.18	43.90	16.66	10.31	56.80
*10		273.0	355.6		6.35	28.80		7.80	34.50		9.27	33.10		9.27	45.70		12.70	59.00
*12		323.9	355.6		6.35	29.90		8.38	35.80		9.53	34.30		10.31	47.40		14.27	61.40
*14		355.6	355.6		7.92	30.50		9.53	36.50		9.53	35.20		11.13	48.30		15.09	62.50

Note: The bevel can be made according to the special requirements of the customers

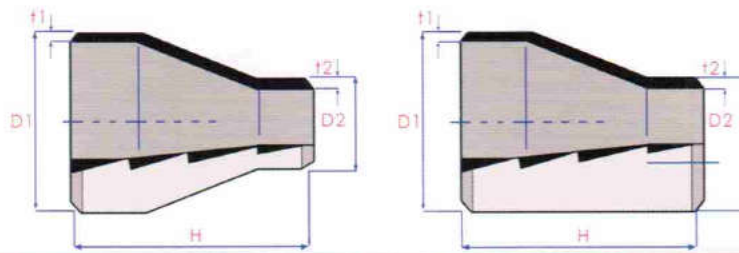

Seamless Welding reducers
ASME/ANSI B16.9

Wall Thickness-Approx.Weight																					Normal Pipe Size (NPS) inch
XS			Sch.80			Sch.100			Sch.120			Sch.140			Sch.160			XXS			
t1 mm	t2 mm	kg	t1 mm	t2 mm	kg	t1 mm	t2 mm	kg	t1 mm	t2 mm	kg	t1 mm	t2 mm	kg	t1 mm	t2 mm	kg	t1 mm	t2 mm	kg	
4.55	3.91	0.17	4.55	3.91	0.17	-	-	-	-	-	-	-	-	-	6.35	5.56	0.22	-	-	-	1 3/4
5.08	3.91	0.27	5.08	3.91	0.27	-	-	-	-	-	-	-	-	-	7.14	5.56	0.51	10.15	7.82	0.67	1 1/2*3/4
	4.55	0.31	4.55	0.31	-	-	-	-	-	-	-	-	-	-	6.35	0.55	-	9.09	0.73	-	*1
	4.85	0.33	4.85	0.33	-	-	-	-	-	-	-	-	-	-	6.35	0.60	-	9.70	0.79	-	*1 1/4
5.54	4.55	0.45	5.54	4.55	0.45	-	-	-	-	-	-	-	-	-	8.74	6.35	0.94	11.07	9.09	1.14	2*1
	4.85	0.53	4.85	0.53	-	-	-	-	-	-	-	-	-	-	6.35	0.99	-	9.70	1.20	-	*1 1/4
	5.08	0.54	5.08	0.54	-	-	-	-	-	-	-	-	-	-	7.14	1.04	-	10.15	1.26	-	*1 1/2
7.01	4.85	0.79	7.01	4.85	0.79	-	-	-	-	-	-	-	-	-	9.53	6.35	1.52	14.02	9.70	2.07	2 1/2*1 1/4
	5.08	0.86	5.08	0.86	-	-	-	-	-	-	-	-	-	-	7.14	1.53	-	10.15	2.10	-	*1 1/2
	5.54	0.94	5.54	0.94	-	-	-	-	-	-	-	-	-	-	8.74	1.65	-	11.07	2.25	-	*2
7.62	5.08	1.04	7.62	5.08	1.04	-	-	-	-	-	-	-	-	-	11.13	7.14	2.12	15.24	10.15	2.76	3*1 1/2
	5.54	1.18	5.54	1.18	-	-	-	-	-	-	-	-	-	-	8.74	2.23	-	11.07	2.90	-	*2
	7.01	1.29	7.01	1.29	-	-	-	-	-	-	-	-	-	-	9.53	2.40	-	14.02	3.12	-	*2 1/2
8.56	5.54	1.78	8.56	5.54	1.78	-	-	-	-	-	-	-	-	-	13.49	8.74	3.97	17.12	11.07	4.85	4*2
	7.01	2.01	7.01	2.01	-	-	-	-	-	-	-	-	-	-	9.53	4.21	-	14.02	5.14	-	*2 1/2
	7.62	2.13	7.62	2.13	-	-	-	-	-	-	-	-	-	-	11.13	4.38	-	15.24	5.35	-	*3
9.53	7.01	3.30	9.53	7.01	3.30	-	-	-	-	-	-	-	-	-	15.88	9.53	6.68	19.05	14.02	8.02	5*2 1/2
	7.62	3.55	7.62	3.55	-	-	-	-	-	-	-	-	-	-	11.13	7.10	-	15.24	8.31	-	*3
	8.56	3.78	8.56	3.78	-	-	-	12.70	11.13	6.09	-	-	-	-	13.49	7.14	-	17.12	8.68	-	*4
10.97	7.62	5.04	10.97	7.62	5.04	-	-	-	-	-	-	-	-	-	18.26	11.13	9.93	21.95	15.24	11.60	6*3
	8.56	5.45	8.56	5.45	-	-	-	14.27	11.13	8.20	-	-	-	-	13.49	10.22	-	17.12	12.00	-	*4
	9.53	5.72	9.53	5.72	-	-	-	12.70	8.65	-	-	-	-	-	15.88	10.78	-	19.05	12.60	-	*5
12.70	8.56	8.44	12.70	8.56	8.44	-	-	-	18.26	11.13	14.00	-	-	-	23.01	13.49	17.30	22.23	17.12	16.70	8*4
	9.53	8.85	9.53	8.85	-	-	-	12.70	14.40	-	-	-	-	-	15.88	17.80	-	19.05	17.20	-	*5
	10.97	9.26	10.97	9.26	-	-	-	14.27	15.00	-	-	-	-	-	18.26	18.40	-	21.95	17.90	-	*6
12.70	9.53	13.00	15.09	9.53	17.60	-	-	-	21.44	12.70	24.40	-	-	-	28.58	15.88	31.60	25.40	19.05	28.40	10*5
	10.97	13.50	10.97	17.90	-	-	-	14.27	24.60	-	-	-	-	-	18.26	32.20	-	21.95	29.00	-	*6
	12.70	14.20	12.70	18.10	18.26	15.09	21.70	-	18.26	25.10	25.40	20.62	29.30	-	23.01	32.50	-	22.23	29.30	-	*8
12.70	10.97	18.40	17.48	10.97	27.30	-	-	-	25.40	14.27	38.70	-	-	-	33.32	18.26	49.40	25.40	21.95	38.70	12*6
	12.70	19.10	12.70	28.40	21.44	15.09	34.40	-	18.26	40.20	28.58	20.62	44.80	-	23.01	51.40	-	22.23	40.20	-	*8
	12.70	19.80	15.09	29.50	18.26	35.70	-	21.44	41.70	25.40	46.30	-	-	-	28.58	53.30	-	25.40	41.70	-	*10
12.70	12.70	34.90	19.05	12.70	53.70	23.83	15.09	66.30	27.79	18.26	76.30	31.75	20.62	86.70	35.71	23.01	95.70	-	-	-	14*8
	12.70	36.10	15.09	59.30	18.26	69.50	-	21.44	80.10	25.40	90.40	-	-	-	28.58	100.40	-	-	-	-	*10
	12.70	37.70	17.48	59.50	21.44	73.30	-	25.40	84.50	28.58	95.40	-	-	-	33.32	106.00	-	-	-	-	*12
12.70	12.70	42.60	21.44	12.07	72.40	26.19	15.09	87.20	30.96	18.26	101.80	36.53	20.62	118.60	40.49	23.01	130.10	-	-	-	16*8
	12.70	43.70	15.09	75.30	18.26	90.60	-	21.44	105.80	25.40	123.30	-	-	-	28.58	135.30	-	-	-	-	*10
	12.70	45.00	17.48	78.20	21.44	94.10	-	25.40	109.90	28.58	128.10	-	-	-	33.32	140.50	-	-	-	-	*12
	12.70	46.30	19.05	79.70	23.83	95.90	-	27.79	111.90	31.75	130.50	-	-	-	35.71	143.10	-	-	-	-	*14

Note: The weight can be made according to the special requirements of the customer.

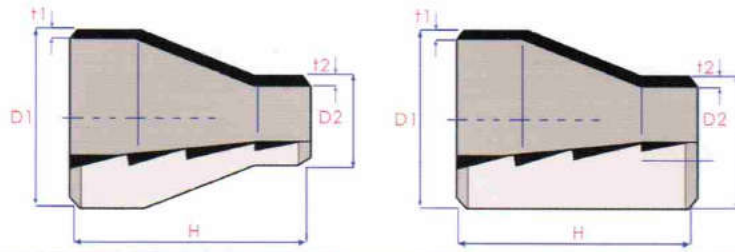

Seamless Welding reducers
ASME/ANSI B 16.9

Normal Size inch	Out side Diameter at Bevel -D1/D2 D1 D2 mm D1 D2	End To End H mm	Sch.No	Approx Weght	Sch.No	Approx Weght
18*16	457*406	381	std	40.5	XS	51.5
*14	*356	381	std	38.12	XS	48.5
*12	*324	381	std	36.7	XS	46.5.7
*10	*273	381	std	34.3	XS	43.5
20*18	508*457	508	std	60.4	XS	76.7
*16	*406	508	std	57.2	XS	72.67
*14	*356	508	std	54.1	XS	68.7
*12	*324	508	std	52	XS	66.2
22*20	559*508	508	std	66.8	XS	84.8
*18	*457	508	std	63.6	XS	80.8
*16	*406	508	std	60.4	XS	76.7
*14	*356	508	std	57.3	XS	72.8
24*22	610*559	508	std	73.2	XS	93.0
20	*508	508	std	70.0	XS	88.9
18	*457	508	std	66.8	XS	84.8
16	*406	508	std	63.6	XS	80.8
26*24	660*610	610	std	95.4	XS	121.2
*22	*559	610	std	91.6	XS	116.4
*20	*508	610	std	87.8	XS	111.5
*18	*457	610	std	84.0	XS	106.6
28*26	711*660	610	std	103.1	XS	130.9
*24	*610	610	std	99.3	XS	126.1
*20	*508	610	std	91.6	XS	116.4
*18	*457	610	std	87.8	XS	111.5
30*28	762*711	610	std	108.0	XS	137.2
*26	*660	610	std	106.9	XS	135.8
*24	*610	610	std	103.1	XS	131.0
*20	*508	610	std	95.5	XS	121.3
32*30	813*762	610	std	118.4	XS	150.4
*28	*711	610	std	114.6	XS	145.5
*26	*660	610	std	110.7	XS	140.6
*24	*610	610	std	101.0	XS	135.9
34*32	864*813	610	std	126.1	XS	160.1
*30	*762	610	std	122.3	XS	155.2
*26	*660	610	std	114.6	XS	145.5
*24	*610	610	std	110.8	XS	140.7
36*34	914*864	610	std	133.7	XS	169.8
*32	*813	610	std	126.8	XS	164.9
*30	*762	610	std	126.0	XS	160.1
*26	*660	610	std	118.3	XS	150.3

Note: The bevel can be made according to the special requirements of the customers

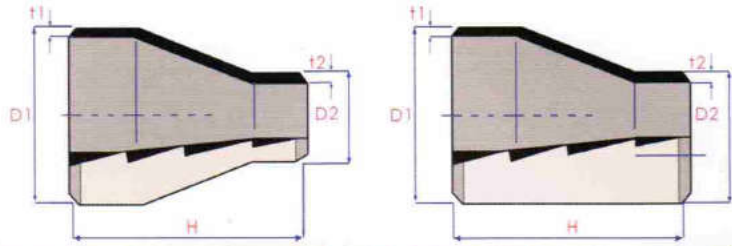

Seamless Welding reducers
ASME/ANSI B16.9

Normal Size inch	Out side Diameter of Bevel :D1/D2 D1 D2 mm D1 D2	End To End H mm	Sch.No	Approx Weght	Sch.No	Approx Weght
38*36	965*914	610	std	141.3	XS	179.4
*34	*864	610	std	137.5	XS	174.6
*32	*813	610	std	133.7	XS	169.8
*30	*762	610	std	129.8	XS	164.9
*28	*711	610	std	126.0	XS	160.0
*26	*667	610	std	122.7	XS	155.8
40*38	1016*965	610	std	148.9	XS	189.1
*36	*914	610	std	145.1	XS	184.3
*34	*864	610	std	141.3	XS	179.5
*32	*813	610	std	137.5	XS	174.6
*30	*762	610	std	133.7	XS	169.8
42*40	1067*1016	610	std	156.6	XS	198.9
*38	*965	610	std	152.8	XS	194.0
*36	*914	610	std	148.9	XS	189.1
*34	*864	610	std	145.1	XS	184.4
*32	*813	610	std	141.3	XS	179.5
*30	*762	610	std	137.5	XS	174.6
44*42	1118*1067	610	std	164.3	XS	208.6
*40	*1016	610	std	160.4	XS	203.7
*38	*965	610	std	165.6	XS	198.9
*36	*914	610	std	152.8	XS	194.0
46*44	1168*1118	610	std	171.9	XS	218.3
*42	*1067	711	std	195.8	XS	248.7
*40	*1016	711	std	191.4	XS	243.0
*38	*965	711	std	186.9	XS	237.4
48*46	1219*1168	711	std	209.1	XS	265.6
*44	*1118	711	std	204.8	XS	260.1
*42	*1067	711	std	200.3	XS	254.4
*40	*1016	711	std	195.8	XS	248.7

Note: The bevel can be made according to the special requirements of the customers

Class 150 Flanges

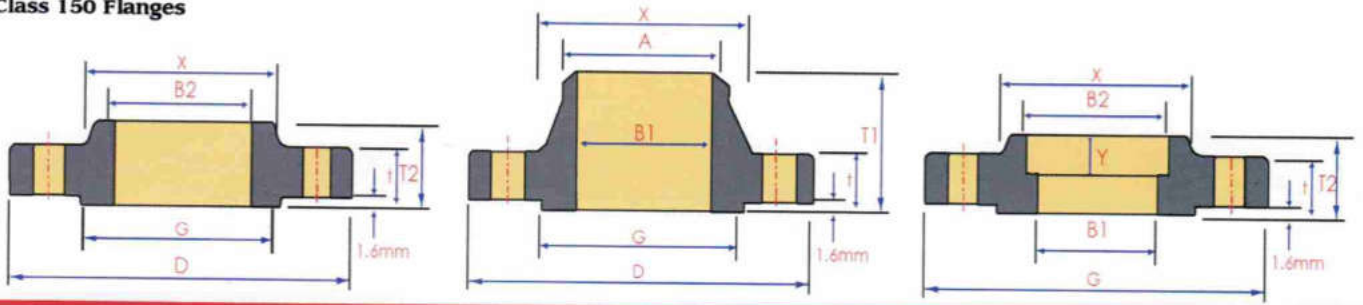

SLIP-ON

WELDING NECK

SOCKETWELDING

ANSI B16.5 FORGED FLANGES

Normal Pipe Size					BORE			LENGTH THRU HUB			Diam.Of Hub at Bevel	Radius of Fillet	Thread Length
	Out side diam	O.D.Of Raised Face	.Diam of based Face	Thickness	Welding Neck Socket Welding	Slip-On Socket Welding	Lap Joint	Welding Neck	Slip-On Threaded Socket Welding	Lap Joint			
	D	G	X	T	B1	B2	B3	T1	T2	T3			
1/2	89	35.1	30.2	11.2	15.7	22.4	22.9	47.8	15.7	15.7	21.3	3.0	15.7
3/4	99	42.9	38.1	12.7	20.8	27.7	28.2	52.3	15.7	15.7	26.7	3.0	15.7
1	108	50.8	49.3	14.2	26.7	34.5	35.1	55.6	17.5	17.5	33.5	3.0	17.5
1 1/4	117	63.5	58.7	15.7	35.1	43.2	43.7	57.2	20.6	20.6	42.2	4.8	20.6
1 1/2	127	73.2	65.0	17.5	40.9	49.5	50.0	62.0	22.4	22.4	48.3	6.4	22.4
2	152	91.9	77.7	19.1	52.6	62.0	62.5	63.5	25.4	25.4	60.5	7.9	25.4
2 1/2	178	104.6	90.4	22.4	62.7	74.7	75.4	69.9	28.4	28.4	73.2	7.9	28.4
3	191	127.0	108.0	23.9	78.0	90.7	91.4	69.9	30.2	30.2	88.9	9.7	30.2
3 1/2	216	139.7	122.2	23.9	90.2	103.4	104.1	71.4	31.8	31.8	101.6	9.7	31.8
4	229	157.2	134.9	23.9	102.4	116.1	116.8	76.2	33.3	33.3	114.3	11.2	33.3
5	254	185.7	163.9	23.9	128.2	143.8	144.5	88.9	36.6	36.6	141.2	11.2	36.6
6	279	215.9	192.0	25.4	154.2	170.7	171.5	88.9	39.6	39.6	168.4	12.7	39.6
8	343	269.7	246.1	28.4	202.7	221.5	222.3	101.6	44.5	44.5	219.2	12.7	44.5
10	406	323.9	304.8	30.2	254.5	276.4	277.4	101.6	49.3	49.3	273.1	12.7	49.3
12	483	381.0	365.3	31.8	304.8	327.2	328.2	114.3	55.6	55.6	323.9	12.7	55.6
14	533	412.8	400.1	35.1	336.6	359.2	360.2	127.0	57.2	79.2	355.6	12.7	57.2
16	597	469.9	457.2	36.6	387.1	410.5	411.2	127.0	63.5	87.4	406.4	12.7	63.5
18	635	533.4	505.0	39.6	438.2	461.8	462.3	139.7	68.3	96.8	457.2	12.7	68.3
20	699	584.2	558.8	42.9	489.0	513.1	514.4	144.5	73.2	103.1	508.0	12.7	73.2
24	813	692.2	663.4	47.8	590.6	616.0	616.0	152.4	82.6	111.3	609.6	12.7	82.6

Note: The bevel can be made according to the special requirements of the customers



Class 300 Flanges

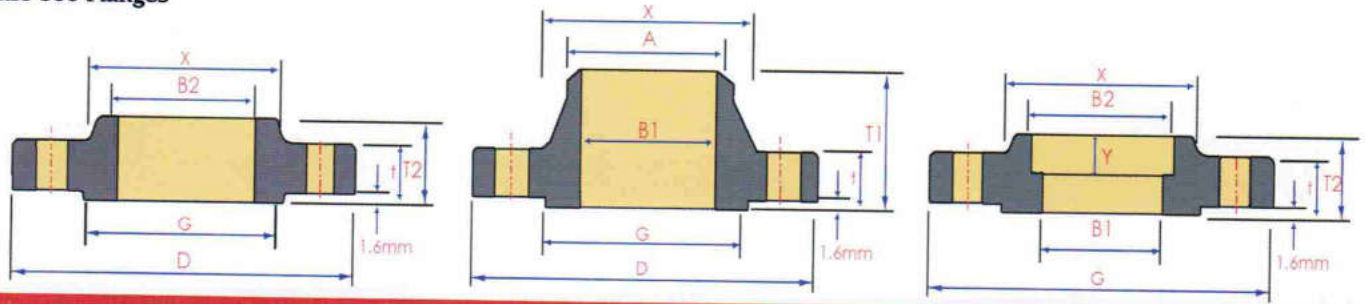

SLIP-ON

WELDING NECK

SOCKETWELDING

ANSI B16.5 FORGED FLANGES

Normal Pipe Size	Out side diam	O.D.Of Raised Face	.Diam of based Face	Thickness	BORE				LENGTH THRU HUB			Diam.Of Hub at Bevel	Radius of Fillet	Thread Length
					Welding Neck Socket Welding	Slip-On Socket Welding	Lap Joint	Counter Bore Min.Thread	Welding Neck	Slip-On Threaded Socket Welding	Lap Joint			
					B1	B2	B3	B	T1	T2	T3			
1/2	95	35.1	38.1	14.2	15.7	22.4	22.9	23.6	52.3	22.4	22.4	21.3	3.0	15.7
3/4	117	42.9	47.8	15.7	20.8	27.7	28.2	29.0	57.2	25.4	25.4	26.7	3.0	15.7
1	124	50.8	53.8	17.5	26.7	34.5	35.1	35.8	62.0	26.9	26.9	33.5	3.0	17.5
1 1/4	133	63.5	63.5	19.1	35.1	43.2	43.7	44.5	65.0	26.9	26.9	42.2	4.8	20.6
1 1/2	155	73.2	69.9	20.6	40.9	49.5	50.0	50.5	68.3	30.2	30.2	48.3	6.4	22.4
2	165	91.9	84.1	22.1	52.6	62.0	62.5	63.5	69.9	33.3	33.3	60.5	7.9	25.4
2 1/2	191	104.6	100.1	25.4	62.7	74.7	75.4	76.2	76.2	38.1	38.1	73.2	7.9	28.4
3	210	127.0	117.3	28.4	78.0	90.7	91.4	92.2	79.2	42.9	42.9	88.9	9.7	30.2
3 1/2	229	139.7	133.4	30.2	90.2	103.4	104.1	104.9	81.0	44.5	44.5	101.6	9.7	31.8
4	254	157.2	146.1	31.8	102.4	116.1	116.8	117.6	85.9	47.8	47.8	114.3	11.2	33.3
5	279	185.7	177.8	36.1	128.2	143.8	144.5	144.5	98.6	50.8	50.8	141.2	11.2	36.6
6	318	215.9	206.2	36.6	154.2	170.7	171.5	171.5	98.6	52.6	52.3	168.4	12.7	39.6
8	381	269.7	260.4	41.1	202.7	221.5	222.3	222.3	111.3	62.0	62.0	219.2	12.7	44.5
10	445	323.9	320.5	47.8	254.5	276.4	277.4	276.4	117.3	66.5	95.3	273.1	12.7	49.3
12	521	381.0	374.7	50.8	304.8	327.2	328.2	328.7	130.0	73.2	101.6	323.9	12.7	55.6
14	584	412.8	425.5	53.8	336.6	369.2	360.2	360.4	142.7	76.2	111.3	355.6	12.7	57.2
16	648	469.9	482.6	47.2	387.1	410.5	411.2	411.2	146.1	82.6	120.7	406.4	12.7	63.5
18	711	533.4	533.4	60.5	438.2	461.8	462.3	462.0	158.8	88.9	130.0	457.2	12.7	68.3
20	775	584.2	587.2	63.5	489.0	513.1	514.4	512.8	162.1	95.3	139.7	508.0	12.7	73.2
24	914	692.2	701.5	69.9	590.6	616.0	616.0	614.4	168.1	106.4	152.4	609.6	12.7	82.6

Note: The bevel can be made according to the special requirements of the customers



Class 300 Flanges

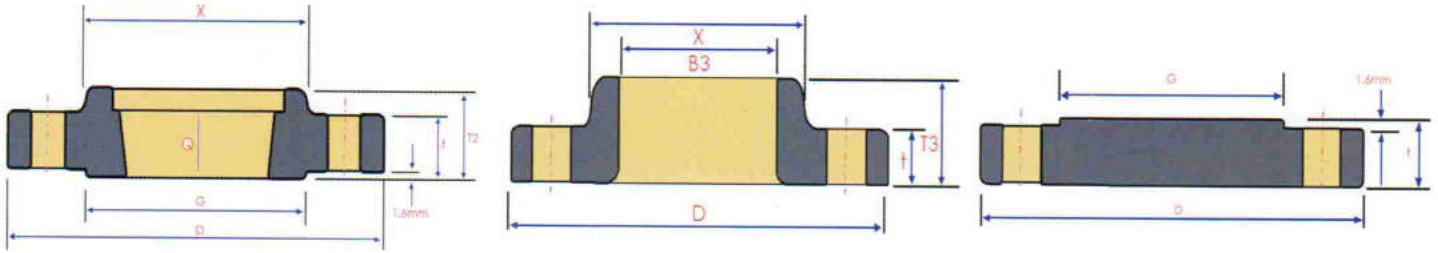

THREADED

LAP JOINT

BLIND

Unit:mm

Normal Pipe Size	Outside Diam Y	DRILLING			BOLTING				APPROXIMATE WEIGHT				
		Bolt Circle Diam	Number of Holes	Diam of Holes	Diam of Holes	Machine Bolt Length		Stud Bolt Length	Welding Neck kg	Slip-on and Threaded kg	Lap joint kg	Blind kg	Socket Welding kg
						Raised Face	Raised Face						
1/2	9.7	66.5	4	15.7	1/2	57.2	63.5	76.2	0.80	0.62	0.61	0.65	0.62
3/4	11.2	82.6	4	19.1	5/8	63.5	76.2	88.9	1.40	1.30	1.30	1.40	1.34
1	12.7	88.9	4	19.1	5/8	63.5	76.2	88.9	1.64	1.50	1.50	1.50	1.55
1 1/4	14.2	98.6	4	19.1	5/8	69.9	82.6	95.3	2.10	1.70	1.70	2.80	1.76
1 1/2	15.7	114.3	4	22.4	3/4	76.2	88.9	101.6	3.06	2.60	2.60	2.80	2.69
2	17.5	127.0	8	19.1	5/8	76.2	88.9	101.6	3.50	3.00	3.00	3.30	3.14
2 1/2	19.1	149.4	8	22.4	3/4	82.6	101.6	114.3	5.31	4.50	4.50	5.40	4.74
3	20.6	168.1	8	22.4	3/4	88.9	108.0	120.7	7.32	5.90	5.80	7.00	6.29
3 1/2	22.4	184.2	8	22.4	3/4	95.3	108.0	127.0	8.2	7.72	7.72	9.53	
4	23.9	200.2	8	22.4	3/4	95.3	114.3	127.0	11.30	10.13	10.07	12.00	
5	23.9	235.0	8	22.4	3/4	108.0	120.7	133.4	15.12	13.00	13.00	16.00	
6	26.9	269.7	12	22.4	3/4	108.0	120.7	139.7	20.00	17.00	16.00	22.00	
8	31.8	330.2	12	25.4	7/8	120.7	139.7	152.4	30.48	26.00	25.00	36.00	
10	33.3	387.4	16	28.4	1	139.7	158.8	171.5	43.74	34.16	39.92	55.34	
12	39.6	450.9	16	31.8	1 1/8	146.1	171.5	184.2	64.41	51.26	60.00	80.00	
14	41.4	514.4	20	31.8	1 1/8	158.8	177.8	190.5	88.30	75.00	85.00	110.00	
16	44.5	571.5	20	35.1	1 1/4	165.1	190.5	203.2	115.00	94.00	112.00	139.25	
18	49.3	628.7	24	35.1	1 1/4	171.5	196.9	209.6	143.00	109.00	135.00	178.00	
20	54.1	685.8	24	35.1	1 1/4	184.2	203.2	222.3	175.00	136.00	165.00	223.17	
24	63.5	812.8	24	41.1	1 1/4	203.2	228.2	254.0	260.00	245.00	250.00	255.00	

Note: The bevel can be made according to the special requirements of the customers

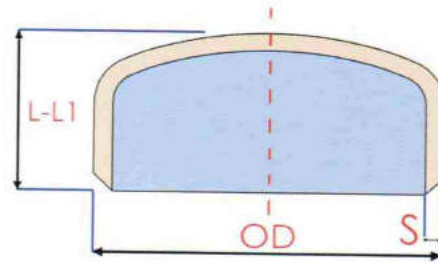

ANSI Caps

inch	OD	L	L1	S=SCHEDULE													
				STD	XS	10	20	30	40	60	80	100	120	140	160	XXS	
1/2	21.3	25.9	25.9	2.77	3.73	-	-	-	2.77	-	3.73	-	-	-	4.75	7.47	
3/4	26.7	31.8	31.7	2.87	3.91	-	-	-	2.87	-	3.91	-	-	-	5.54	7.82	
1	33.4	38.1	38.1	2.38	4.55	-	-	-	3.38	-	4.55	-	-	-	6.35	9.09	
1 1/4	42.4	38.1	38.1	3.56	4.85	-	-	-	3.56	-	4.85	-	-	-	6.35	9.70	
1 1/2	48.3	38.1	38.1	3.68	5.08	-	-	-	3.68	-	5.08	-	-	-	7.14	10.16	
2	60.3	38.1	44.4	3.91	5.54	-	-	-	3.91	-	5.54	-	-	-	8.71	11.07	
2 1/2	73.0	38.1	50.8	5.16	7.01	-	-	-	5.16	-	7.01	-	-	-	9.52	14.02	
3	88.9	50.8	63.5	5.49	7.62	-	-	-	5.49	-	7.62	-	-	-	11.12	15.25	
3 1/2	101.6	63.5	76.2	5.74	8.08	-	-	-	5.74	-	8.08	-	-	-	-	-	
4	114.3	63.5	76.2	6.02	8.56	-	-	-	6.02	-	8.56	-	11.12	-	13.49	17.12	
5	141.3	76.2	88.9	6.55	9.52	-	-	-	6.55	-	9.52	-	12.70	-	15.87	19.05	
6	168.3	88.9	101.6	7.11	10.97	-	-	-	7.11	-	10.97	-	14.27	-	18.24	21.94	
8	219.1	101.6	127.0	8.18	12.70	-	6.35	7.04	8.18	10.13	12.70	15.06	18.24	20.62	23.01	22.22	
10	273.0	127.0	152.4	9.27	12.70	-	6.35	7.80	9.27	12.70	15.06	18.24	21.41	25.40	28.57	26.40	
12	323.8	152.4	177.8	9.52	12.70	-	6.35	8.38	10.31	14.30	17.45	21.41	25.40	28.57	33.32	26.40	
14	355.6	165.1	190.5	9.52	12.70	6.35	7.92	9.52	11.12	15.10	19.05	23.80	27.76	31.75	35.71	-	
16	406.4	177.8	203.2	9.52	12.70	6.35	7.92	9.52	12.70	16.70	21.41	26.19	30.94	36.52	40.46	-	
18	457.2	203.2	228.6	9.52	12.70	6.35	7.92	11.12	14.27	19.05	23.80	29.36	34.92	39.67	45.24	-	
20	508.0	228.6	254.0	9.52	12.70	6.35	9.52	12.70	15.06	20.60	26.19	32.54	38.10	44.45	49.99	-	
22	558.8	254.0	279.4	9.52	12.70	6.35	9.52	12.70	-	-	-	-	-	-	-	-	
24	609.6	266.7	304.8	9.52	12.70	6.35	9.52	14.25	17.45	24.60	30.94	38.89	46.02	52.37	59.51	-	
26	660.4	266.7	266.7	9.52	12.70	7.92	12.70	-	-	-	-	-	-	-	-	-	
28	711.2	266.7	266.7	9.52	12.70	7.92	12.70	15.88	-	-	-	-	-	-	-	-	
30	762.0	266.7	266.7	9.52	12.70	7.92	12.70	15.88	-	-	-	-	-	-	-	-	
32	812.8	266.7	266.7	9.52	12.70	7.92	12.70	15.88	17.45	-	-	-	-	-	-	-	
34	863.6	266.7	266.7	9.52	12.70	7.92	12.70	15.88	17.45	-	-	-	-	-	-	-	
36	914.4	266.7	266.7	9.52	12.70	7.92	12.70	15.88	19.05	-	-	-	-	-	-	-	
38	965.2	266.7	266.7	9.52	12.70	7.92	12.70	15.88	19.05	-	-	-	-	-	-	-	
40	1016.0	266.7	266.7	9.52	12.70	7.92	12.70	15.88	19.05	-	-	-	-	-	-	-	
42	1066.8	266.7	266.7	9.52	12.70	7.92	12.70	15.88	19.05	-	-	-	-	-	-	-	
44	1117.6	266.7	266.7	9.52	12.70	7.92	12.70	15.88	19.05	-	-	-	-	-	-	-	
46	1168.4	266.7	266.7	9.52	12.70	7.92	12.70	15.88	19.05	-	-	-	-	-	-	-	
48	1219.2	266.7	266.7	9.52	12.70	7.92	12.70	15.88	19.05	-	-	-	-	-	-	-	

Note: The bevel can be made according to the special requirements of the customers

WROUGHT CARBON STEEL WALL THICKNESS STANDARD

normal pipe size		nominal wall thickness										normal pipe size									
A	B	ASME	JIS	DIN	JIS(1)	DIN(2)	SCH10	SCH20	SCH80	STD	SCH40	SCH60	XS	SCH80	SCH100	SCH120	SCH140	SCH160	XXS	A	B
15	1/2	21.3	21.7	21.3	2.8	2.0	2.11	-	2.41	2.77	2.77	-	3.73	3.73	-	-	-	4.78	7.47	15	1/2
20	3/4	26.7	27.2	26.9	2.8	2.3	2.11	-	2.41	2.87	2.87	-	3.91	3.91	-	-	-	5.56	7.82	20	3/4
25	1	33.4	34.0	33.7	3.2	2.6	2.77	-	2.90	3.38	3.38	-	4.55	4.55	-	-	-	6.35	9.09	25	1
32	1 1/4	42.2	42.7	42.4	3.5	2.6	2.77	-	2.97	3.56	3.56	-	4.85	4.85	-	-	-	6.35	9.70	32	1 1/4
40	1 1/2	48.3	48.6	48.3	3.5	2.6	2.77	-	3.18	3.68	3.68	-	5.08	5.08	-	-	-	7.14	10.15	40	1 1/2
20	2	60.3	60.5	60.3	3.8	2.9	2.77	-	3.18	3.91	3.91	-	5.54	5.54	-	-	-	8.74	11.07	50	2
65	2 1/2	73.0	76.3	76.1	4.2	2.9	3.05	-	4.78	5.16	5.16	-	7.01	7.01	-	-	-	9.53	14.02	65	2 1/2
80	3	88.9	89.1	88.9	4.2	3.2	3.05	-	4.78	5.49	5.49	-	7.62	7.62	-	-	-	11.13	15.24	80	3
90	3 1/2	101.6	101.6	-	4.2	-	3.05	-	4.78	5.74	5.74	-	8.08	8.08	-	11.13	-	-	-	90	3 1/2
100	4	114.3	114.3	114.3	4.5	3.6	3.05	-	4.78	6.02	6.02	-	8.56	8.56	-	12.70	-	13.49	17.12	100	4
125	5	141.3	139.8	139.7	4.5	4.0	3.40	-	-	6.55	6.55	-	10.97	10.97	-	14.27	-	15.88	19.05	125	5
150	6	168.3	168.3	168.3	5.0	4.5	3.40	4.5	-	7.11	7.11	-	12.70	12.70	15.09	18.26	20.62	18.26	21.95	150	6
200	8	219.1	219.3	219.1	5.8	6.3	3.76	6.35	7.04	8.18	8.18	10.31	12.70	15.09	18.26	21.44	25.40	23.01	28.58	200	8
250	10	273.1	273.1	273.0	6.6	6.3	4.19	6.35	7.80	9.27	9.27	12.70	17.48	21.44	25.40	28.58	33.32	25.40	30.01	250	10
300	12	323.9	328.9	323.9	6.9	7.1	4.57	6.35	8.38	9.53	10.31	14.27	19.05	23.83	27.79	31.75	35.71	25.40	30.01	300	12
350	14	355.6	355.6	355.6	7.9	8.0	6.35	7.92	9.53	9.53	11.13	15.09	21.44	26.19	30.96	36.53	40.49	-	-	350	14
400	16	406.4	406.4	406.4	7.9	8.8	6.35	7.92	9.53	9.53	12.70	16.66	23.83	29.36	34.93	39.67	45.24	-	-	400	16
450	18	457.2	457.2	457.0	7.9	10.0	6.35	7.92	11.13	9.53	14.27	16.05	22.70	26.19	32.54	38.10	44.45	50.01	-	450	18
500	20	508.0	508.0	508.0	7.9	11.0	6.35	9.53	12.70	9.53	15.09	20.62	27.70	28.58	34.93	41.28	47.63	53.98	-	500	20
550	22	558.8	558.8	-	-	-	6.35	9.53	12.70	9.53	-	22.23	30.96	38.89	46.02	52.37	59.54	-	-	550	22
600	24	609.6	609.6	610.0	-	12.5	6.35	9.53	14.27	9.53	17.48	24.61	30.96	-	-	-	-	-	-	600	24
650	26	660.4	660.4	-	-	-	7.92	12.70	15.88	9.53	-	-	30.96	-	-	-	-	-	-	650	26
700	28	711.1	711.2	711.0	-	12.5	7.92	12.70	15.88	9.53	-	-	30.96	-	-	-	-	-	-	700	28
750	30	762.0	762.0	-	-	-	7.92	12.70	15.88	9.53	-	-	30.96	-	-	-	-	-	-	750	30
800	32	812.8	812.8	813.0	-	12.5	7.92	12.70	15.88	9.53	17.48	-	30.96	-	-	-	-	-	-	800	32
850	34	863.6	863.6	-	-	-	7.92	12.70	15.88	9.53	17.48	-	30.96	-	-	-	-	-	-	850	34
900	36	914.4	914.4	914.0	-	12.5	7.92	12.70	15.88	9.53	19.05	-	30.96	-	-	-	-	-	-	900	36
950	38	965.2	965.2	-	-	-	-	-	-	9.53	-	-	30.96	-	-	-	-	-	-	950	38
1000	40	1016.0	1016.0	1016.0	-	12.5	-	-	-	9.53	-	-	30.96	-	-	-	-	-	-	1000	40
1050	42	1066.8	1066.8	-	-	-	-	-	-	9.53	-	-	30.96	-	-	-	-	-	-	1050	42
1100	44	1117.6	1117.6	-	-	-	-	-	-	9.53	-	-	30.96	-	-	-	-	-	-	1100	44
1150	46	1168.4	1168.4	-	-	-	-	-	-	9.53	-	-	30.96	-	-	-	-	-	-	1150	46
1200	48	1219.2	1219.2	1220.0	-	-	-	-	-	9.53	-	-	30.96	-	-	-	-	-	-	1200	48

IIS G34502 ASME B36.10M
JIS G3454 DIN2448
JIS G3455 DIN 2458
JIS G3457

Note: The bevel can be made according to the special requirements of the customers



The General Material

Variety	Chemical Composition % max													Mechanical Requirements				
	Standard Cod	Grade	C	Mn	P	S	Si	Cr	Mo	Ni	CU	Other	σb Mpa min	σ0.2 Mpa min	δ % min	HB max	Other	
FITTING	ASTM A420/A420M	WPL6	0.30	0.60-1.35	0.035	0.040	0.15-0.30	0.30	0.12	0.40	0.40	c b: 0.02 ; v: 0.08	415-585	240	22	-	%30	
		WPL9	0.20	0.40-1.60	0.30	0.030	0.13-0.37	-	-	1.60-2.24	0.75-1.25	-	435-610	315	20	-	%45	
	ASTM/A515/A515M	WPL3	0.20	0.31-0.64	0.05	0.05	0.13-0.37	-	-	3.2-3.8	-	-	450-620	240	22	-	%30	
		WPLB	0.13	0.90	0.030	0.030	0.10	-	-	8.4-9.6	-	-	690-865	515	16	-	%30	
FORGING	ASTM/A515/A515M	UNS S1800	0.30	2.0	0.030	0.020	0.10-0.35	21.0-23.0	2.50-3.50	4.50-6.50	-	n: 0.08 - 0.20	620-795	450	25	290	%45	
		A105	0.035	0.65-1.05	0.035	0.040	0.50-1.00	0.30	0.12	0.40	0.40	v: 0.05 ; n b: 0.02	485	250	22	187	%30	
	ASTM A182/A182	F11CL1	0.05-0.15	0.30-0.60	0.030	0.030	0.50-1.00	1.00-1.50	0.44-0.65	-	-	-	415	205	20	121-174	%50	
		F11CL2	0.10-0.20	0.30-0.80	0.040	0.040	0.50-1.00	1.00-1.50	0.44-0.65	-	-	-	485	275	20.0	143-207	%50	
		F11CL3	0.10-0.20	0.30-0.80	0.040	0.040	0.50	1.00-1.50	0.44-0.65	-	-	-	515	310	20	156-207	%50	
		F12CL1	0.10-0.20	0.30-0.60	0.045	0.040	0.10-0.60	0.80-1.25	0.44-0.65	-	-	-	415	205	20	121-174	%50	
		F12CL2	0.10-0.20	0.30-0.80	0.040	0.040	1.00	0.80-1.25	0.44-0.65	-	-	-	485	275	20.0	143-207	%50	
		F304	0.08	2.00	0.045	0.030	1.00	18.0-20.0	-	-	8.0-11.0	-	n: 0.10	515	205	30	-	%50
		F404H	0.04-0.10	2.00	0.045	0.030	1.00	18.0-20.0	-	-	8.0-11.0	-	-	515	205	30	-	%50
		F304L	0.035	2.00	0.045	0.030	1.00	18.0-20.0	-	-	8.0-13.0	-	n: 0.10	485	170	30	-	%50
		F316L	0.035	2.00	0.045	0.030	1.00	16.5-18.0	2.00-3.00	-	10.0-15.0	-	-	485	170	30	-	%50
		F317	0.08	2.00	0.045	0.030	1.00	18.0-20.0	3.0-4.0	-	11.0-15.0	-	-	515	205	30	-	%50
		F321	0.08	2.00	0.045	0.030	1.00	17.0-19.0	-	-	9.0-12.0	-	H: 5 C: %0.7	515	205	30	-	%50
		F347	0.08	2.00	0.045	0.030	1.00	17.0-20.0	-	-	9.0-13.0	-	H: 10 C: %1.10	515	205	30	-	%50
PIPE	ASTM/A515/A515M	B	0.30	1.20	0.05	0.045	-	0.40	0.15	0.40	0.40	v: 0.08	415	240	see stan	-	-	
		C	0.35	0.29-1.06	0.035	0.035	0.10min	0.40	0.15	0.40	0.40	v: 0.08	415	240	22	-	-	
	ASTM A312/A312M	TP304	0.08	2.00	0.040	0.030	0.75	18.0-20.0	-	-	8.0-11.0	-	v: 0.08	485	275	20	-	-
		TP304H	0.04-0.10	2.00	0.040	0.030	0.75	18.0-20.0	-	-	8.0-11.0	-	-	515	205	35	-	-
		TP304L	0.035	2.00	0.040	0.030	0.75	18.0-20.0	-	-	8.0-13.0	-	-	485	170	35	-	-
		TP316L	0.035	2.00	0.040	0.030	0.075	16.0-18.0	2.00-3.00	-	10.0-15.0	-	-	485	205	35	-	-
		TP321	0.15	0.30-0.60	0.040	0.030	0.075	17.0-20.0	-	-	9.0-13.0	-	H: 5 C: %0.7	515	205	35	-	-
		P5	0.15	0.30-0.60	0.025	0.025	0.50	4.00-6.00	0.44-0.65	-	-	-	-	415	205	22	-	-
		P58	0.12	0.30-0.60	0.025	0.025	1.00-2.00	4.00-6.00	0.44-0.65	-	-	-	-	415	205	22	-	-
		P5C	0.15	0.30-0.60	0.025	0.025	0.50	8.00-10	0.44-0.65	-	-	-	-	415	205	22	-	-
		P9	0.15	0.30-0.60	0.025	0.025	0.50-1.00	00	0.90-1.10	-	-	-	-	415	205	22	-	-
		P11	0.05-0.15	0.30-0.61	0.025	0.025	0.50-1.00	1.00-1.50	0.44-0.65	-	-	-	-	415	205	22	-	-
		P12	0.05-0.15	0.30-0.61	0.025	0.025	0.50	0.80-1.25	0.44-0.65	-	-	-	-	415	220	22	-	-
		P22	0.05-0.15	0.30-0.60	0.025	0.025	0.50	1.90-2.60	0.87-1.13	-	-	-	-	415	205	22	-	-
P91	0.05-0.15	0.30-0.60	0.025	0.010	1.20-0.50	8.00-9.50	0.85-1.05	-	0.40	-	see standard	585	415	20	-	-		
PLATE	ASTM A515/A515M	60	0.24	0.98	0.035	0.035	0.13-0.45	-	-	-	-	-	415-550	220	25	-	-	
		65	0.28	0.98	0.035	0.035	0.13-0.45	-	-	-	-	-	450-585	240	23	-	-	
		70	0.31	1.30	0.035	0.035	0.13-0.45	-	-	-	-	-	485-620	-	21	-	-	

Note: The bevel can be made according to the special requirements of the customers

The index of material chemical composition and mechanical properties shall change as to some defined condition and please refer to the original standard



The General Material

Standard Cod	Grade	Chemical Composition % max											Mechanical Requirements							
		C	Mn	P	S	Si	Cr	Mo	Ni	Cu	Other	σ_b Mpa min	$\sigma_{0.2}$ Mpa min	δ min	HB max	Other				
ASTM A234/A234M	WPB	0.30	0.29-1.06	0.050	0.058	0.10min	0.40	0.15	0.40	0.40		0.15	0.40	0.40		415-585	240	22	197	-
	WPC	0.35	0.29-1.06	0.050	0.058	0.10min	0.40	0.15	0.40	0.40		0.15	0.40	0.40	v0.06:nb0.02	485-655	275	22	197	-
	WPI	0.28	0.30-0.90	0.045	0.045	0.10-0.50	-	0.44-0.65	-	-	-	0.44-0.65	-	-	-	380-550	205	22	197	-
	WP12CL1	0.05-0.20	0.30-0.80	0.045	0.045	0.60	0.80-1.25	0.44-0.65	-	-	-	0.44-0.65	-	-	-	415-585	220	22	197	-
	WP12CL2	0.05-0.20	0.30-0.80	0.045	0.045	0.60	0.80-1.25	0.44-0.65	-	-	-	0.44-0.65	-	-	-	485-655	275	22	197	-
	WP11CL1	0.05-0.20	0.30-0.60	0.030	0.030	0.50-1.00	1.00-1.50	0.44-0.65	-	-	-	0.44-0.65	-	-	-	415-585	205	22	197	-
	WP11CL2	0.05-0.20	0.30-0.80	0.040	0.040	0.50-1.00	1.00-1.50	0.44-0.65	-	-	-	0.44-0.65	-	-	-	485-655	275	22	197	-
	WP11CL3	0.05-0.20	0.30-0.80	0.040	0.040	0.50-1.00	1.00-1.50	0.44-0.65	-	-	-	0.44-0.65	-	-	-	520-650	310	22	197	-
	WP22CL1	0.05-0.15	0.30-0.60	0.040	0.040	0.50	1.90-2.60	0.87-1.13	-	-	-	0.87-1.13	-	-	-	415-585	205	22	197	-
	WP22CL3	0.05-0.15	0.30-0.60	0.040	0.040	0.50	1.90-2.60	0.87-1.13	-	-	-	0.87-1.13	-	-	-	520-690	310	22	197	-
	WP5CL1	0.15	0.30-0.60	0.040	0.030	0.50	4.0-0.6	0.87-1.13	-	-	-	0.87-1.13	-	-	-	415-585	205	22	197	-
	WP5CL3	0.15	0.30-0.60	0.040	0.030	0.50	4.0-0.6	0.44-0.65	-	-	-	0.44-0.65	-	-	-	520-690	310	22	217	-
	WP9CL1	0.15	0.30-0.60	0.030	0.030	1.00	8.0-10.0	0.90-1.10	-	-	-	0.90-1.10	-	-	-	415-585	205	22	217	-
	WP9CL3	0.15	0.30-0.60	0.030	0.030	1.00	8.0-10.0	0.90-1.10	-	-	-	0.90-1.10	-	-	-	520-690	310	22	217	-
WPR	0.20	0.40-1.06	0.045	0.050	-	-	-	-	1.60-2.24	0.75-1.25	-	-	-	-	435-650	315	20/28	217	-	
WP91	0.08-0.12	0.30-0.60	0.020	0.010	0.20-0.50	8.0-9.5	0.85-1.05	-	0.40	-	0.85-1.05	-	-	see standard	585-760	415	20	217	-	
WP911	0.09-0.13	0.30-0.60	0.020	0.010	0.10-0.50	8.0-10.5	0.90-1.10	-	0.40	-	0.90-1.10	-	-	see standard	620-840	440	20	248	-	
WP304	0.08	2.00	0.045	0.030	1.00	18.0-20.0	-	-	8.0-11.0	-	-	-	-	-	515	205	28	248	-	
WP304H	0.04-0.10	2.00	0.045	0.030	1.00	18.0-20.0	-	-	8.0-11.0	-	-	-	-	-	515	205	28	-	-	
WP304L	0.035	2.00	0.045	0.030	1.00	18.0-20.0	-	-	8.0-13.0	-	-	-	-	-	485	170	28	-	-	
WP304LN	0.030	2.00	0.045	0.030	0.75	18.0-20.0	-	-	8.0-10.5	-	-	-	-	n2.010 - 0.16	515	205	28	-	-	
WP304N	0.08	2.00	0.045	0.030	0.75	18.0-20.0	-	-	8.0-11.0	-	-	-	-	n2.010 - 0.16	550	240	28	-	-	
WP309	0.15	2.00	0.045	0.030	1.00	22.0-24.0	-	-	12.0-15.0	-	-	-	-	-	515	205	28	-	-	
WP310	0.15	2.00	0.045	0.030	1.50	24.0-26.0	-	-	19.0-22.0	-	-	-	-	-	515	205	28	-	-	
WP316	0.08	2.00	0.045	0.030	1.00	16.0-18.0	2.00-3.00	-	10.0-14.0	-	2.00-3.00	-	-	-	515	205	28	-	-	
WP316H	0.04-0.10	2.00	0.045	0.030	1.00	16.0-18.0	2.00-3.00	-	10.0-14.0	-	2.00-3.00	-	-	-	515	205	28	-	-	
WP316LN	0.030	2.00	0.045	0.030	0.75	16.0-18.0	2.00-3.00	-	11.0-14.0	-	2.00-3.00	-	-	n2.010 - 0.16	515	205	28	-	-	
WP316L	0.035	2.00	0.045	0.030	1.00	16.0-18.0	2.00-3.00	-	10.0-16.0	-	2.00-3.00	-	-	-	485	170	28	-	-	
WP316N	0.08	2.00	0.045	0.030	0.75	16.0-18.0	2.00-3.00	-	11.0-14.0	-	2.00-3.00	-	-	n2.010 - 0.16	550	240	28	-	-	
WP317	0.08	2.00	0.045	0.030	1.00	18.0-20.0	3.0-4.0	-	11.0-15.0	-	3.0-4.0	-	-	-	515	205	28	-	-	
WP317L	0.030	2.00	0.045	0.030	1.00	18.0-20.0	3.0-4.0	-	11.0-15.0	-	3.0-4.0	-	-	-	515	205	28	-	-	
WP321	0.08	2.00	0.045	0.030	1.00	17.0-20.0	-	-	9.0-13.0	-	-	-	-	ti:5c - 0.7	515	205	28	-	-	
WP321H	0.04-0.10	2.00	0.045	0.030	1.00	17.0-20.0	-	-	9.0-13.0	-	-	-	-	ti:4c - 0.7	515	205	28	-	-	
WP347	0.08	2.00	0.045	0.030	1.00	17.0-20.0	-	-	9.0-13.0	-	-	-	-	nb+ta:10c - 1.10	515	205	28	-	-	
WP347H	0.04-0.10	2.00	0.045	0.030	1.00	17.0-20.0	-	-	9.0-13.0	-	-	-	-	nb+ta:8c - 1.10	515	205	28	-	-	
WP348	0.08	2.00	0.045	0.030	1.00	17.0-20.0	-	-	9.0-13.0	-	-	-	-	ta:0.10	515	205	28	-	-	
WP348H	0.04-0.010	2.00	0.045	0.030	1.00	17.0-20.0	-	-	9.0-13.0	-	-	-	-	ta:0.10	515	205	28	-	-	

FITTING

Note: The bevel can be made according to the special requirements of the customers



TECHNICAL PARAMETER

Technical Parameters Of Seamless Steel Pipe

20#Q345:API5LB, ASTM A106 GR.B, ASTM A53 GR.B, GB5310 - 1995, GB6479 - 2000, GB9948 - 2000, GB3087 - 1999, GB/T8163 - 1999, GB/T8162 - 1999, GB/T17396 - 1998

The common materials: 20# and Q345. Technical standard: API5L B, ASTM A106 GR.B, ASTM A53 GR.B: High-pressure boiler pipe GB5310- 1995, Special pipe for fertilizer making GB6479 - 2000, pipe for petroleum crating GB9948 - 2000, low & medium pressure boiler pipe GB/T8163 - 1999, structural pipe GB/T8162 - 1999 & hydraulic support medium pressure boiler pipe GB3087 - 1999, fluid pipe GB/T8163 - 1999, structural pipe GB/T8162 - 1999 and hydraulic support pipe GB/T17396 - 1998

A53 A53 Chemical components and mechanical property

STAN- dard	Trand mark	Chemical components										Mechanical Property		
		C	Si	Mn	P	S	Cu	Ni	Mo	Cr	V	Tensile Strength (Mpa)	Yield Strength (Mpa)	Elongation (%)
ASTM	A	≤0.25	/	≤0.95	≤0.05	≤0.06	≤0.40	≤0.40	≤0.15	≤0.40	≤0.08	≥330	≥205	≥29.5
A53	B	≤0.30	/	≤0.1	≤0.05	≤0.06	≤0.40	≤0.40	≤0.15	≤0.40	≤0.08	≥415	≥240	≥29.5

A106 A106 Chemical components and mechanical property

STAN- dard	Trand mark	Chemical components										Mechanical Property		
		C	Si	Mn	P	S	Cu	Ni	Mo	Cr	V	Tensile Strength (Mpa)	Yield Strength (Mpa)	Elongation (%)
ASTM	A	≤0.25	/	≤0.95	≤0.035		≤0.40	≤0.40	≤0.15	≤0.40	≤0.08	≥415	≥240	≥30
A106	B	≤0.30	/	≤1.0	≤0.035		≤0.40	≤0.40	≤0.15	≤0.40	≤0.08	≥485	≥275	≥30

A179 A179 Chemical components and mechanical property

STAN- dard	Trand mark	Chemical components										Mechanical Property		
		C	Si	Mn	P	S	Cu	Ni	Mo	Cr	V	Tensile Strength (Mpa)	Yield Strength (Mpa)	Elongation (%)
ASTM A179	A179	0.06- 0.18	/	0.27- 0.63	≤0.035		/	/	/	/	/	≥325	≥180	35

A192 A192 Chemical components and mechanical property

STAN- dard	Trand mark	Chemical components										Mechanical Property		
		C	Si	Mn	P	S	Cu	Ni	Mo			Tensile Strength (Mpa)	Yield Strength (Mpa)	Elongation (%)
ASTM A192	A192	0.06- 0.18	≤0.25	0.27- 0.63	≤0.035		/	/	/			≥325	≥180	≥35

Note: The bevel can be made according to the special requirements of the customers

370 370 Chemical components and mechanical property

Trademark	Chemical components					Mechanical Property		
	C	Si	Mn	P	S	Tensile Strength	Yield Strength	Elongation
						(Mpa)	(Mpa)	(%)
STPG 370	≤0.25	≤0.35	0.30 ~ 0.90	≤0.040	≤0.040	≥370	≥216	30
STS 370	≤0.25	0.10 ~ 0.35	0.30 ~ 1.10	≤0.035	≤0.035	≥370	≥215	30
STPT 370	≤0.25	0.10 ~ 0.35	0.30 ~ 0.90	≤0.035	≤0.035	≥370	≥215	30

A213 A213 Chemical components and mechanical property

STAN- dard	Trand mark	Chemical components									Mechanical Property			
		C	Si	Mn	P	S	Cu	Ni	Mo	Cr	V	Tensile Strength	Yield Strength	Elongation
												(Mpa)	(Mpa)	(%)
ASTM A213	A213T11	0.05-0.15	≤0.05	0.30-0.60	≤0.025	/	/	0.44-0.65	1.0-1.5	/	/	≥415	≥170	≥30
	A213T12	0.05-0.15	≤0.05	0.30-0.61	≤0.025	/	/	0.44-0.65	0.80-1.25	/	/	≥415	≥205	≥30
	A213T22	0.05-0.15	≤0.05	0.30-0.60	≤0.025	/	/	0.87-1.13	1.90-2.60	/	/	≥415	≥205	≥30

A210 A210 Chemical components and mechanical property

STAN- dard	Trand mark	Chemical components									Mechanical Property			
		C	Si	Mn	P	S	Cu	Ni	Mo	Cr	V	Tensile Strength	Yield Strength	Elongation
												(Mpa)	(Mpa)	(%)
ASTM A210	A210A1	≤0.27	≥0.10	≤0.93	≤0.35	/	/	/	/	/	/	≥415	≥255	≥30
	A210C	≤0.35	≥0.10	0.29-1.06	≤0.35	/	/	/	/	/	/	≥485	≥275	≥30

PSL1: Chemical components and mechanical property

Class and Sort	Chemical components				Mechanical Property				
	C(max)	Mn(max)	P(max)	S(max)	Tensile Strength(min.)		Yield Strength(min.)		
					psi	Mpa	psi	Mpa	
A25	CL I	0.21	0.60	0.030	0.030	45,000	310	25,000	172
	CL II	0.21	0.60	0.030	0.030				
A		0.22	0.90	0.030	0.030	48,000	331	30,000	207
B		0.28	1.20	0.030	0.030	60,000	414	35,000	241
X42		0.28	1.30	0.030	0.030	60,000	414	42,000	290
X46		0.28	1.40	0.030	0.030	63,000	434	46,000	317
X52		0.28	1.40	0.030	0.030	66,000	455	52,000	359
X56		0.28	1.40	0.030	0.030	71,000	490	56,000	386
X60		0.28	1.40	0.030	0.030	75,000	517	60,000	414
X65		0.28	1.40	0.030	0.030	77,000	531	65,000	448
X70		0.28	1.40	0.030	0.030	82,000	565	70,000	483

Note: The bevel can be made according to the special requirements of the customers



Class and Sort	Chemical components				Mechanical Property							
	C(max)	Mn(max)	P(max)	S(max)	Tensile Strength(min.)		Tensile Strength(max)		Yield Strength(min.)		Yield Strength(max)	
					psi	Mpa	psi	Mpa	psi	Mpa	psi	Mpa
B	0.24	1.20	0.025	0.015	60.000	414	110.00	758	35.00	241	65.000	758
X42	0.24	1.30	0.025	0.015	60.000	414	110.00	758	42.00	290	72.000	758
X46	0.24	1.40	0.025	0.015	63.000	434	110.00	758	46.00	317	76.000	758
X52	0.24	1.40	0.025	0.015	66.000	455	110.00	758	52.00	359	77.000	758
X56	0.24	1.40	0.025	0.015	71.000	490	110.00	758	56.00	386	79.000	758
X60	0.24	1.40	0.025	0.015	75.000	517	110.00	758	60.00	414	82.000	758
X65	0.24	1.40	0.025	0.015	77.000	531	110.00	758	65.00	448	87.000	758
X70	0.24	1.40	0.025	0.015	82.000	565	110.00	758	70.00	483	90.000	758
X80	0.24	1.40	0.025	0.015	90.000	621	120.00	827	80.00	552	100.000	827

API 5CT Chemical components and mechanical property

Class	Sort	Chemical components											Mechanical Property							
		C		Mn		Mo		Cr		Ni	Cu	P	S	Si	Yield Strength (Mpa)		Tensile Strength (Mpa)		Hardness	
		min	max	min	max	min	max	min	max	max	max	max	max	max	min	max	min	max	HRC	HBW /HRC
H40	/	/	/	/	/	/	/	/	/	/	/	0.030	0.030	/	276	552	414	/	/	
J55	/	/	/	/	/	/	/	/	/	/	/	0.030	0.030	/	379	552	517	/	/	
K55	/	/	/	/	/	/	/	/	/	/	/	0.030	0.030	/	379	552	655	/	/	
N80	1	/	/	/	/	/	/	/	/	/	/	0.030	0.030	/	552	758	689	/	/	
	0	/	/	/	/	/	/	/	/	/	/	0.030	0.030	/	552	758	689	/	/	
M65	/	/	/	/	/	/	/	/	/	/	/	0.030	0.030	/	448	586	586	22	235	
	1	/	0.43	/	1.90	/	/	/	/	0.25	0.35	0.030	0.030	0.45	552	655	655	23	241	
L80	9cr	/	0.15	0.30	0.60	0.90	1.10	8.0	10.00	0.50	0.25	0.020	0.010	1.00	552	655	655	23	241	
	13cr	0.15	0.22	0.25	1.00	/	/	12.0	14.00	0.50	0.25	0.020	0.010	1.00	552	655	655	23	241	
C90	1	/	0.35	/	1.00	0.25	0.75	/	1.20	0.99	/	0.020	0.010	/	621	724	689	25.4	255	
	2	/	0.50	/	1.90	/	NL	/	NL	0.99	/	0.030	0.010	/	621	724	689	25.4	255	
T95	1	/	0.35	/	1.20	0.25	0.85	0.40	1.50	0.99	/	0.020	0.010	/	655	758	724	25.4	255	
	2	/	0.50	/	1.90	/	/	/	/	0.99	/	0.030	0.010	/	655	758	724	25.4	255	
P110	/	/	/	/	/	/	/	/	/	/	/	0.030	0.030	/	758	965	862	/	/	

Tolerances of Outer Diameter and Wall Thickness

Standard	Tolerances of Outer Diameter		Wall Thickness	
	mm	mm	mm	mm
	Out Diameter	Tolerances of Outer Diameter	Outer Diameter ≤130mm	Outer Diameter >130mm
GB/T8162 - 1999	>50	+1%	S ≤ 4 4-20 S > 20	S ± 12.5% +15%-10% ± 12.5%
GB/T8163 - 1999	ALL	+1% min +0.5mm Tolerances of hot-finished steel pipe	ALL	+15%-10%
ASTM A53	<48.3 >60.3	+0.4mm-0.79mm +1%	ALL	± 12.5%
ASTM A106	<48.3 48.3 - 114.3 >114.3	+0.4mm-0.79mm +0.79mm +1.59mm-0.79mm	ALL	± 12.5%
GB9948 - 1988	<159 >159	+1% +1.25%	S ≤ 20 S > 20	± 12.5% +10%

Note: The bevel can be made according to the special requirements of the customers



TECHNICAL PARAMETER

Seamless Steel Pipe				
Alloy pipe	Cr5Mo.(P5.STFA25 T5)15CrMo(P11.12 STFA22)13CrMo44 12Cr 1MoV P22(10CrMo 910) T91.P91.P9 T9Wb36	GB5310 - 95 GB9948 - 88 ASTMA335/A335M ASTMA213/213M DIN17175 - 79 JISG3467 - 88 JISG3458 - 88	Φ16 - 824*2 - 100	The Seamless steel pipe features resistance to high pressure,high/low temperature and corrosion and is used in the industries of petroleum chemical engineering and electric power as well as boiler
High - Pressure boiler pipe	20G.A106 ST45.8/III	GB5310 - 95 ASTMA106 - 99 DIN 17175 - 79	Φ14 - 630*2 - 80	Temperature-resistant seamless steel pipe for high-pressure boiler
High- pressure seamless pipe for petroleum cracking and fertilizer making equipments	20.12crMo.15CrMo	GB9948 - 88	Φ10 - 530*1.5 - 36	Boiler pipe for refinery, heat exchanging pipe,seamless steel pipe fort pipeline
	20.16Mo.Q345	GB6479 - 2000	Φ18 - 530*3 - 40	Fertilizer making equipment and pipe line
Low-and medium pressure boiler pipes	10 . 20	GB3087 - 1999	Φ10 - 530*2 - 40	Over - Heat pipe for low-and medium - pressure boiler boiling water pipe locomotive smoke pipe big and small
Fluid pipe	Q345 . 20	GB/T8163 - 1999	Φ 8 - 630*1.0 - 40	
Structural Pipe	10 20. 35 45.16Mn.Q345B	GB/T8162 - 1999	Φ6 - 1020*1.5 100	
Line pipe	B	API	Φ60 - 630*1.5 - 40	carrying gas,water or oil in the industries of petroleum and natural gas
Hydraulic prop pipe	27SiMn	GB/T17396 - 1988	Φ70 - 377*9 - 40	
Ship pipe	410	GB/T5312 - 1999	Φ14 - 426*1.5 - 45	Pipe for ship,boiler and over - heater

Note:The bevel can be made according to the special requirements of the customers





نیکا صنعت 

Head uarters :No.14,ground Floor ,110Passage
Afkhami Alley Tel:+98 21 33943320 Fax:+98 21 33942249
Khayame North . Ave Tehran - Iran
Factory:No.1Sanaye St. Lapeh Zanak Sahrak
Khavaran Road Tehran - Iran

تهران:خیابان خیام شمالی .کوچه افخمی
پاساژ ۱۱۰.مکف .پلاک ۱۴
تلفن : ۰۲۱ - ۳۳۹۴۳۳۲۰ فاکس : ۰۲۱ - ۳۳۹۴۲۲۴۹
کارخانه :تهران - جاده خاوران .شهرک صنعتی لپه زنک
خیابان صنایع . پلاک ۴